

AIRCRAFT WHEEL & BRAKE DIVISION

PARKER HANNIFIN CORPORATION

AVON, OHIO

PARTS LIST

199-189 HEAT SHIELD KIT FOR

40-202/239 WHEEL ASSEMBLIES

<u>PARKER P/N</u>	<u>DESCRIPTION</u>	<u>QUANTITY</u>
157-01600	Heat Shield Clip	9
(B) 205-04400	Key Drive	18
(B) 105-09900	Rivet/MS20426-AD4-9	36
(A)(B) ESB7032	Engineering Service Bulletin	1
(B)(C) 157-01900	Heat Shield	9

NOTE:

THIS KIT WILL CONVERT ONE WHEEL.

199-189
NC 1-9-91 (302-29)
REV. A, 7-8-91 (303-75)
REV. B, 9-7-93 (309-28)
REV. C, 10-13-93 (309-59)
RJR

Cleveland

Wheels & Brakes

Parker Hannifin Corporation

Aircraft Wheel & Brake

1160 Center Road, P.O. Box 158

Avon, Ohio 44011 USA

1-800-BRAKING (272-5464)

216-937-1272 • FAX 216-937-5409

SERVICE BULLETIN

DRIVE KEY MODIFICATION FOR 40-202, 40-239 AND 40-239A WHEEL ASSEMBLIES

SUBJECT: Replacement of 205-00801 Drive Keys and 105-01700 Rivets with 205-04400 Drive Keys, 105-09900 Rivets and 157-01900 Heat Shields as used on Cleveland Wheel Models 40-202, 40-239 and 40-239A.

PURPOSE: To improve the fit between the drive key and the wheel half, to improve the rivet clinch, to eliminate the 157-01600 Heat Shield Clip cracking problem and to reduce the wheel assembly weight.

APPLICABILITY:

1. Cessna Citation Models 500 and 550 (per STC SA1297GL approved Main Wheel and Brake Conversion).
2. Cessna Citation Models 501 and 551 (per STC SA1298GL approved Main Wheel and Brake Conversion).
3. Cessna Citation Model S550 (per STC SA1441GL approved Main Wheel and Brake Conversion).
4. Cessna Citation Model S550 original equipment production Wheel Assembly 40-202.

EFFECTIVITY: September, 1993 and after.

COMPLIANCE: Optional. At owner's discretion.

MATERIAL

REQUIRED: Two (2) 199-189 Heat Shield Kits are required to retrofit one aircraft.

NOTE: Existing 205-00801 Drive Keys and 105-01700 Rivets must be replaced by 205-04400 Drive Keys, 105-09900 Rivets and 157-01900 Heat Shields supplied in kit.

PROCEDURE:

1. Removal of 157-01600 Heat Shields and 205-00801 Drive Keys.
 - A. Jack aircraft per aircraft Maintenance Manual until tire is clear of ground and fully deflate tire. Remove lockwire securing screws on hubcap subassembly.
 - B. Remove screws and hubcap subassembly from outer wheel half subassembly.
 - C. Remove and retain two screws securing axle nut and anti-skid transducer, then remove and retain axle nut and tanged washer.
 - D. Remove wheel assembly from axle and place on a clean flat surface.

SERVICE BULLETIN

- E. Break tire beads away from both wheel flanges by applying pressure in even increments around entire sidewall as close to tire beads as possible.
 - F. Remove nuts, bolts and washers.
 - G. Separate the wheel halves and remove tire.
 - H. Grind or file off shop heads of rivets, being careful not to damage inner wheel half.
 - I. Punch out rivets, being careful not to enlarge or damage rivet holes.
 - J. Remove and discard drive keys and heat shield segments.
2. Installation of 157-01600 Heat Shield Clips, 205-04400 Drive Keys, 157-01900 Heat Shields and 105-09900 Rivets.
- A. Using one .125 dia. Cleco, fasten a 157-01900 Heat Shield, one 205-04400 Drive Key and one 157-01600 Heat Shield Clip to the inner wheel half as shown in Figure 1.

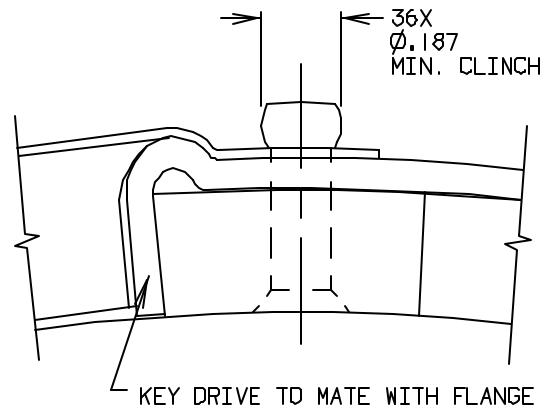

Figure 1

- B. Install one 105-09900 Rivet through the C'sunk side of the wheel, through the hole adjacent to the CLECO (in the wheel half, heat shield, drive key and heat shield clip).



SERVICE BULLETIN

- C. Squeeze the rivet and inspect to insure that the .187 min. clinch diameter requirement is obtained.
- D. Repeat this procedure to install all eighteen 205-04400 Drive Keys, nine 157-01900 Heat Shields, nine 157-01600 Heat Shield Clips and eighteen 105-09900 Rivets.
- E. Place Outer Wheel Half Subassembly on work surface with flange down. Clean wheel flange, bead seat, register and packing groove with a cloth dampened with isopropyl alcohol.
- F. Lubricate a new O-ring (P/N 101-24100) with Dow Molykote 55M grease and install in wheel register.
- G. Place serviceable 22 x 8.0-10, 12-ply tubeless tire over outer wheel half subassembly.
- H. Position inner wheel half subassembly in tire so lightening holes in both wheel halves are aligned.
- I. Lubricate bolt and nut threads and bearing surfaces of bolt heads, washers and nuts with antiseize compound, specification MIL-T-5544. Slide a countersunk washer onto each bolt, then slide bolts through inner wheel half subassembly.

CAUTION: Countersunk side of washer must be toward the bolt head or bolt failure may result. Install bolt heads on Inner Wheel Half.

- J. Compress wheel halves and install a washer and a nut on each bolt.
- K. Torque nuts to a final Lubtork value of 300 in-lb.
- L. When all nuts have been torqued, torque a second time to insure the required value has been achieved. Often, O-ring compression will give a FALSE initial reading.
- M. Place wheel/tire assembly in an inflation cage for initial inflation. Inflate tire just enough to seat the beads. Reduce tire pressure to recommended storage pressure (40 psi) and remove wheel/tire assembly from inflation cage.

WARNING: Do not inflate tire to full operating pressure until wheel assembly has been mounted on aircraft.

- N. Carefully align the wheel and tire assembly with the axle and align the wheel key slots with the brake disc drive tangs.

CAUTION: MAKE CERTAIN THAT THE DRIVE TANGS ARE ENGAGED IN THE WHEEL KEY SLOTS.

- O. Install bearing cone and grease seal into outer wheel half hub.

SERVICE BULLETIN

- P. Install axle nut as follows:
1. Apply MIL-G-81322 bearing grease to axle threads and axle nut threads, and to all load-bearing surfaces of the axle nut and tanged washer.
 2. Place tanged washer in position on axle and rotate axle nut onto the axle until it is snug.
 3. Tighten axle nut to 100 inch-pounds while manually rotating the wheel. Back off the nut to zero in-lb., but with all the parts still seated.
 4. Retorque axle nut to 50 in-lb. while manually rotating the wheel. If not at a locking position, advance the nut to the nearest locking position.
- Q. Secure antiskid transducer and axle nut with two screws and lockwire as required.
- R. Snap drive coupling, which is attached to the hubcap, onto antiskid transducer and attach hubcap onto outer wheel half assembly with three screws.
- NOTE: Use care that the drive coupling engages the antiskid transducer drive shaft when installing the hub cap.**
- S. Lockwire hubcap screws as required.
- T. Inflate tire to required pressure per manual.
- U. Lower aircraft and remove jacks.
- V. Make a log book entry referencing this activity and return aircraft to service.