

# Component Maintenance Manual for External Design Wheels and Brakes

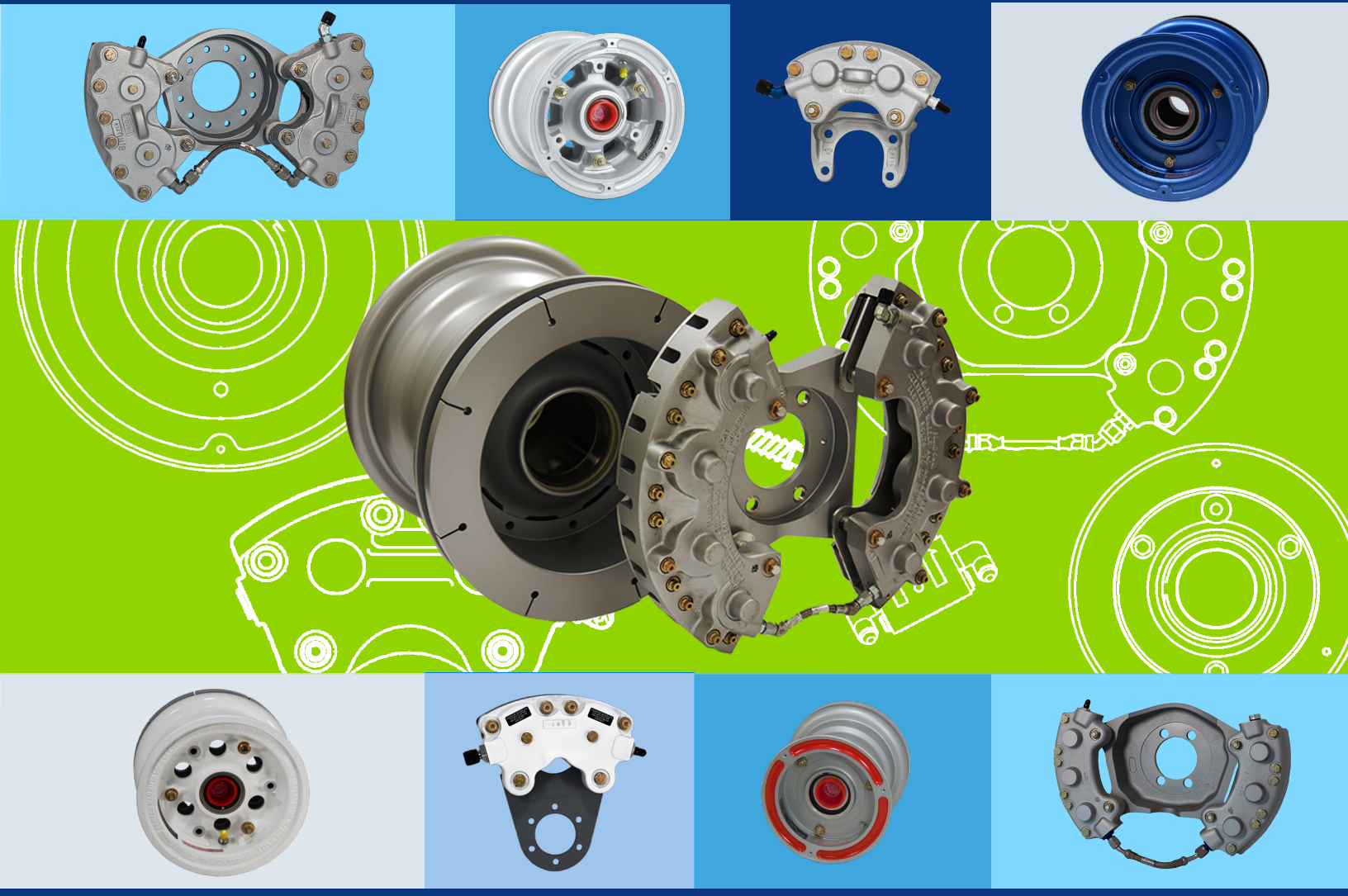

AWBCMM0001-33

# COMPONENT MAINTENANCE MANUAL

Publication Number: **AWBCMM0001-33/USA**  
AWBCMM0001 Issue 33, Dated: **March 24, 2026**

## Reference

### MANUALS

Refer to the applicable Component Maintenance Manual for detailed maintenance / overhaul procedures. Consult the Aircraft Maintenance Manual and Airframe Log Books (for optional installations) to confirm the approved part numbers for the particular aircraft application. If any inconsistencies are observed in this data, please notify Cleveland Wheel & Brake Systems Customer Support.

### IMPORTANT NOTE

Use of other manufacturer's components with original Cleveland Wheel & Brake Systems assemblies will void the Cleveland Wheel & Brake Systems warranty.

#### **SAFETY WARNING**



**FAILURE OR IMPROPER SELECTION OR IMPROPER USE OF THE PRODUCTS AND/OR SYSTEMS DESCRIBED HEREIN OR RELATED ITEMS CAN CAUSE DEATH, PERSONAL INJURY AND PROPERTY DAMAGE.**

This document and other information from Cleveland Wheel & Brake Systems (CWBS) and authorized distributors provide product and/or system options for further investigation by users having technical expertise. It is important that you analyze all aspects of your application, including consequences of any failure, and review the information concerning the product or system at [clevelandwheelandbrake.com](http://clevelandwheelandbrake.com) using the Products category pages or the Find by Aircraft function. Due to the variety of operating conditions and applications for these products or systems, the user, through its own analysis and testing, is solely responsible for making the final selection of the products and systems and assuring that all performance, safety and warning requirements of the application are met.

The products described herein, including without limitation, product features, specifications, designs, availability and pricing, are subject to change by CWBS at any time without notice.

### CONTACT INFORMATION

Cleveland Wheel & Brake Systems, 1160 Center Road • Avon, Ohio 44011

[www.clevelandwheelandbrake.com](http://www.clevelandwheelandbrake.com)

E-mail: [clevelandwbhelp@clevelandwbs.com](mailto:clevelandwbhelp@clevelandwbs.com)

Customer Support Fax: 440-937-5409

Technical Service Hotline: 1-800-BRAKING (1-800-272-5464)

Literature Requests: [www.veryon.com](http://www.veryon.com)

© 2025 Aircraft Wheel and Brake, LLC

**Revision Highlights****Revision 33, dated March 24, 2026**

<b>Page</b>	<b>Description of Change</b>
Front Cover	Updated artwork
Back Cover	Updated artwork
311	The length of time that an assembly can be stored is governed by its seals. Product assemblies kept in storage for an extended time without actuation can accelerate compression set in assembled seals. Compression set occurs when the seal fails to recover its form after extended time under squeeze and/or extreme temperature. It is best practice to disassemble any assembly kept in storage without actuation for one year or more and rebuild it with new seals prior to installation on aircraft. End users may utilize alternative storage intervals if product does not exhibit any appreciable effect on performance. For uninstalled seals stored under optimal conditions, current aerospace practices recognize a 60-quarter shelf life for nitrile seals; all other seals have unlimited uninstalled shelf life. The storage life may be shortened by exposure to sunlight, extreme temperatures, humidity, ozone, contamination of fluids, severe operating conditions, etc.
A-3	Added the following brake discs to the min thickness table 564-02000, 564-21600, 564-22201, 564-22202
B-2	B5. Primers and Paints updated MIL-PRF-26915A removed P/N 11011-10014
C-2	C1. Brake Assembly / Lining Cross-Reference Table updated 30-163: Lining 066-15300 30-163 RH: Lining 066-15300 30-182: Lining 066-15300



**Table of Contents**

<b><u>SUBJECT</u></b>	<b><u>PAGE</u></b>
LIST OF FIGURES .....	3
LIST OF TABLES.....	3
INTRODUCTION.....	4
PART NUMBERING SYSTEM.....	6
DESCRIPTION AND OPERATION.....	7
1. Wheel and Brake Assemblies.....	7
2. Brake Assemblies.....	8
3. Wheel Assemblies.....	9
SECTION 100 - TROUBLESHOOTING.....	101
1. General.....	101
2. Brake Assembly Troubleshooting.....	101
3. Wheel Assembly Troubleshooting.....	104
SECTION 200 - ON-AIRCRAFT MAINTENANCE.....	201
1. General.....	201
2. Brake Assembly On-Aircraft Inspection and Maintenance.....	201
A. Brake Inspection.....	201
B. Corrective Maintenance of Brakes.....	201
(1) Replacement of Metallic Brake Linings.....	202
(2) Replacement of Organic Brake Linings.....	204
(6) Lining Conditioning Procedures.....	209
3. Wheel Assembly On-Aircraft Inspection and Maintenance.....	210
A. Nose and Tail Wheel Inspection.....	210
B. Main Wheel Inspection.....	210
4. Tire On-Aircraft Inspection and Maintenance.....	210
SECTION 300 - OFF-AIRCRAFT MAINTENANCE.....	301
1. General.....	301
2. Brake Assembly Off-Aircraft Maintenance.....	301
A. Removal From Aircraft.....	301
B. Brake Disassembly.....	302
(1) Disassembly Procedures.....	302
(2) Lining Removal.....	305
(3) Anchor Bolt Removal.....	306
C. Inspection.....	307
D. Brake Reassembly.....	309
(1) Reassembly Procedures.....	309
(2) Installation of Pistons.....	310
(3) Lining Installation.....	310
(4) Further Reassembly of Brake Components.....	310
E. Storage.....	311
3. Wheel Assembly Off-Aircraft Maintenance.....	311
A. Bearing Grease.....	312
B. Removal From Aircraft.....	312
(1) Removal of Main Wheel.....	312
(2) Removal of Nose Wheel.....	313
(3) Removal of Tail Wheel.....	314

**Table of Contents**

<b><u>SUBJECT</u></b>	<b><u>PAGE</u></b>
C. Wheel Disassembly.....	315
(1) Tire Removal .....	315
(2) Bearing Cone Removal .....	316
(3) Inflation Valve Removal.....	317
(4) Bearing Cup Removal .....	317
D. Inspection.....	318
E. Wheel Reassembly .....	321
(1) Bearing Cup Installation .....	321
(2) Tire Mounting.....	322
(3) Disc Installation .....	323
(a) Brake Disc Attached with Wheel Tie Bolts.....	323
(b) Brake Disc Not Attached with Wheel Tie Bolts .....	324
(4) Inflation Valve Installation.....	325
(5) Bearing Installation.....	325
(6) Tire Inflation.....	326
F. Storage .....	326
4. Brake and Wheel Refinishing .....	327
A. Degreasing .....	327
B. Paint Removal.....	328
C. Surface Pretreatment.....	329
D. Repainting .....	330
5. Installation of Brake and Wheel Assemblies Onto Aircraft.....	332
A. Brake Installation.....	332
B. Wheel Installation .....	333
(1) Main Wheel .....	333
(2) Nose Wheel.....	334
(3) Tail Wheel.....	335
APPENDIX A - WEAR LIMITS AND TORQUE VALUES .....	A-1
A1. Brake Lining Wear Limits .....	A-1
A2. Brake Disc Minimum Thickness .....	A-2
A3. Back Plate Tie Bolt Torque .....	A-4
A4. Wheel Assembly Torque Values.....	A-8
A5. Tire Inflation Valve Stem Torque.....	A-11
APPENDIX B - SPECIAL TOOLS / LUBRICANTS / REPAIR MATERIALS.....	B-1
B1. Special Tools .....	B-1
B2. Lubricants For Elastomeric Compounds .....	B-1
B3. Lubricants .....	B-1
B4. Surface Repair .....	B-2
B5. Primers and Paints.....	B-2
B6. Chemical Stripping Agents.....	B-2
APPENDIX C - BRAKE ASSEMBLY / LINING CROSS-REFERENCE .....	C-1
C1. Brake Assembly / Lining Cross-Reference .....	C-1

**List of Figures and Tables**

<b><u>FIGURES</u></b>	<b><u>PAGE</u></b>
1 Typical External Wheel and Brake .....	7
2 Typical External Disc Brake.....	9
3 Typical Nose/Tail Wheel Assembly.....	11
4 Typical Main Wheel Assembly.....	12
201 Pin Installation, Metallic Lining .....	203
202 Rivet Installation, Organic Lining.....	206
203 Pressure Plate Straightening.....	207
204 Rivet/Pin Installation, Acceptance Criteria For Metallic and Organic Linings.....	207
205 Installation of 066-00504 Lining to Brake Shoe.....	208
301 External Piston Guide.....	303
302 Internal Piston Guide.....	305
303 Anchor Bolt Removal.....	306
304 Cylinder To Back Plate Surface Inspection .....	307
305 Anchor Bolt Installation.....	309
306 Tire Removal .....	316
307 Bearing Cup Removal .....	317
308 Bead Seat Inspection .....	318
309 Disc Coning Limits.....	320
310 Disc Inspection .....	320
311 Bearing Cup Installation .....	322
312 Wheel Tie Bolts .....	324
313 Pack Bearing Cones.....	325
314 Typical Torque Plate (Cast), Painted Surfaces.....	330
315 Typical Brake Cylinder, Painted Surfaces .....	331
316 Typical Wheel Half, Painted Surfaces .....	331
A1 Minimum Lining Thickness .....	A-1
A1-1 Disc Wear Measurement (Piper Aztec) .....	A-1
A2 Disc Thickness Measurement.....	A-2
A3 Back Plate Tie Bolts .....	A-4

<b><u>TABLES</u></b>	<b><u>PAGE</u></b>
-- Units of Measure .....	5
101 Brake Assembly Troubleshooting .....	101
102 Wheel Assembly Troubleshooting.....	104

## Introduction

---

### General

There are a variety of publications available from Cleveland Wheel & Brake Systems (CWBS) to assist in the maintenance, overhaul or troubleshooting of CWBS products. These documents are intended to supplement, not replace, the airframe manufacturer's instructions when CWBS products are used. The "Component Maintenance Manual" (CMM) is an excellent reference publication used by many installers and technicians. It has been generically written to address the common practices and procedures used to inspect, troubleshoot and overhaul most General Aviation external type wheels and brakes. The CMM is often used in conjunction with resources found at [clevelandwheelandbrake.com](http://clevelandwheelandbrake.com) where you can find detailed illustrated assembly breakdowns. The more complex internal type wheels and brakes generally have a manual expressly written for their overhaul and maintenance type activities.

### Manual Use

Use of this manual requires reference to the CWBS website, [clevelandwheelandbrake.com](http://clevelandwheelandbrake.com) where the Product category pages, Find by Aircraft function or other search methods can be used to find resources related to the assembly being maintained. Examples of these resources may include a product exploded view with bill of materials, service bulletins, component maintenance manuals and product reference memos.

The term "cylinder assembly" or "caliper" is a reference to a brake assembly which includes the cylinder in addition to a back plate, pressure plate, brake linings, piston(s), and other components.

The term "cylinder" is used to identify the housing for the piston(s), o-rings, and brake fluid. The cylinder is a component of the caliper.

When referencing the CWBS website, [clevelandwheelandbrake.com](http://clevelandwheelandbrake.com) you may note terms "cylinder assembly" and "caliper" being used interchangeably.

### Manual Updates

The manual publication number will reflect the latest issue in effect with a suffix "-X" (X being the latest issue), e.g. AWBCMM0001-33. The publication number will advance numerically with each update issued. Each page will reflect the latest issue in effect. Refer to the **Revision Highlights Page** in this publication for details of each update.

Consult the CWBS website for current publications, [www.clevelandwheelandbrake.com](http://www.clevelandwheelandbrake.com) or contact CWBS Technical Support.

For technical assistance, contact CWBS Technical Support:

[clevelandwbhelp@clevelandwbs.com](mailto:clevelandwbhelp@clevelandwbs.com)

1-800-BRAKING (272-5464)

Fax: 440-937-5409

**Introduction**Units of Measure

The measurements used in this manual are presented in U.S. Standard Units with metric equivalents in parentheses after or below the U.S. units. Conversions and abbreviations are listed in the following table:

U.S. Standard Unit	U.S. Standard Abbreviation	Corresponding Metric Unit	Metric Abbreviation
degrees Fahrenheit	°F	degrees Celsius	°C
foot pounds	ft-lb	Newton-meter	N·m
gallon	gal	liter	l
inch	in.	millimeter	mm
inch pounds	in-lb	Newton-meter	N·m
mile	mi	kilometer	km
miles per hour	mph	kilometers/hour	km/hr
ounce	oz	milliliter	ml
pounds per square inch	psi	kilopascals	kPa

Abbreviations

Abbreviations used in this manual are listed and defined below.

**para** .... paragraph      **P/N** .... part number      **ref** .... reference

**Part Numbering System**

Two part numbering methods have been used by Cleveland over the years to identify products. The long form is an eight-digit (computer friendly) number and is used to identify detail and subassembly parts. The short form can contain both alpha and numeric characters. Past practices used the short form number on all of the products. Current practice is the use of the eight-digit format to identify all detail and subassembly components. Top assemblies are identified using the FAA TSO approval. These are usually short form numbers, but occasionally are long form, or neither form, depending on the era in which the approval was granted.

To convert from the short form to the long form use the following method:

1. Examples of converting older short version part numbers to the current eight-digit format is shown below:

Example: 65-144 becomes 065-14400

2. For numbers not ending in 00, replace the last two digits with a letter using the table below as a reference.

Example: 65-144C becomes 065-14403

01=A	06=F	11=L	16=R	21=W
02=B	07=G	12=M	17=S	22=X
03=C	08=H	13=N	18=T	23=Y
04=D	09=J	14=P	19=U	24=Z
05=E	10=K	15=Q	20=V	

Letter I and O are deleted, so as not to be confused with the numbers 1 and 0.

**Description and Operation**

1. Wheel and Brake Assemblies

All wheel and brake combinations, Reference Figure 1, are matched components and qualified as such in accordance with Technical Standard Order (TSO) C26. Unauthorized substitution of wheel and brake components is a violation of the TSO of which the units are jointly qualified, and is prohibited.

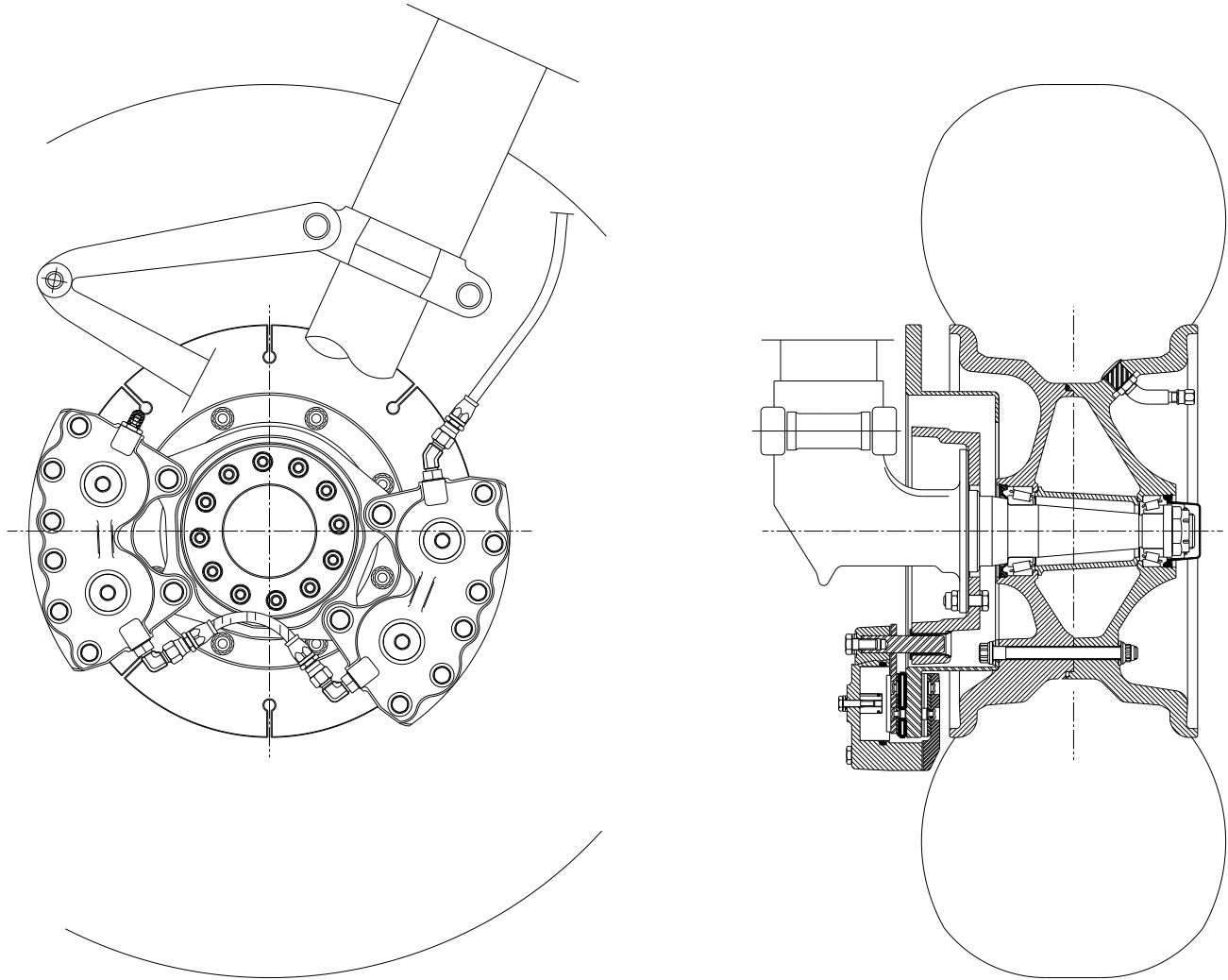

Figure 1 - Typical External Wheel and Brake

**Description and Operation**

---

**2. Brake Assemblies**

The brake assembly and disc combination have been designed and qualification tested in accordance with Technical Standard Order (TSO) C26 and specific aircraft requirements to properly and safely decelerate the aircraft under various conditions. Unauthorized substitution of components can compromise brake effectiveness, is a violation of the qualification basis, and is prohibited.

**A. Brake Description**

The brake is an external caliper-type design. The cylinder (1), Ref. Figure 2, is a cast aluminum or magnesium housing. The pistons (7) are contained by the cylinder and form a pressure vessel for the brake fluid. Two anchor bolts are press fitted into the cylinder and are retained with nuts (12) and washers (13). The pressure plate (5) is held in position by the two anchor bolts. Back plate (4) is secured to the cylinder with bolts (2) and washers (3) on the opposite side of the brake disc. The back plate and pressure plate each hold brake linings (11). The cylinder is allowed to slide or float in torque plate (16) bushings. The torque plate is mounted to the landing gear axle. The caliper (cylinder assembly) is the assembly which includes the cylinder, pistons, back and pressure plates, linings, and other related components. Back plate to cylinder insulator shim (18) and piston to pressure plate insulator disc (17) are typically found on calipers that use the metallic based lining only. Specific illustrated parts breakdown for brake assemblies may be found at [clevelandwheelandbrake.com](http://clevelandwheelandbrake.com).

**B. Brake Operation**

Hydraulic pressure, applied via the pilot's and co-pilot's master cylinders, enters the brake via lines connected to an inlet fitting on the caliper. The pressure then flows through the cylinder and forces the pistons outward against the pressure plate. The caliper should be free to slide on the torque plate assembly bushings allowing both pressure plate and back plate linings to contact the brake which will in turn contact the brake disc at precisely the same time.

The braking action generates a torque which transmits a braking force converting the kinetic energy into heat which is absorbed by the brake disc and surrounding components. This braking force is transmitted to the wheel and into the tire, bringing the aircraft to a stop. Whenever a maximum energy Rejected Take Off (RTO) has occurred the intrinsic heat buildup can be quite severe and the components are to be inspected for airworthiness and overhauled in accordance with these procedures or procedures established by the airframe manufacturer. Releasing toe pedal pressure will allow the hydraulic pressure to decay in the brake caliper removing pressure from the disc. The wheel should be free to rotate with minimal drag. Some caliper designs incorporate a mechanism on the piston that will retract the piston and attached pressure plate lining away from the disc. These units are self-adjusting and retract to obtain approximately 0.02 to 0.04 inch of lining clearance to the disc.

**Description and Operation**

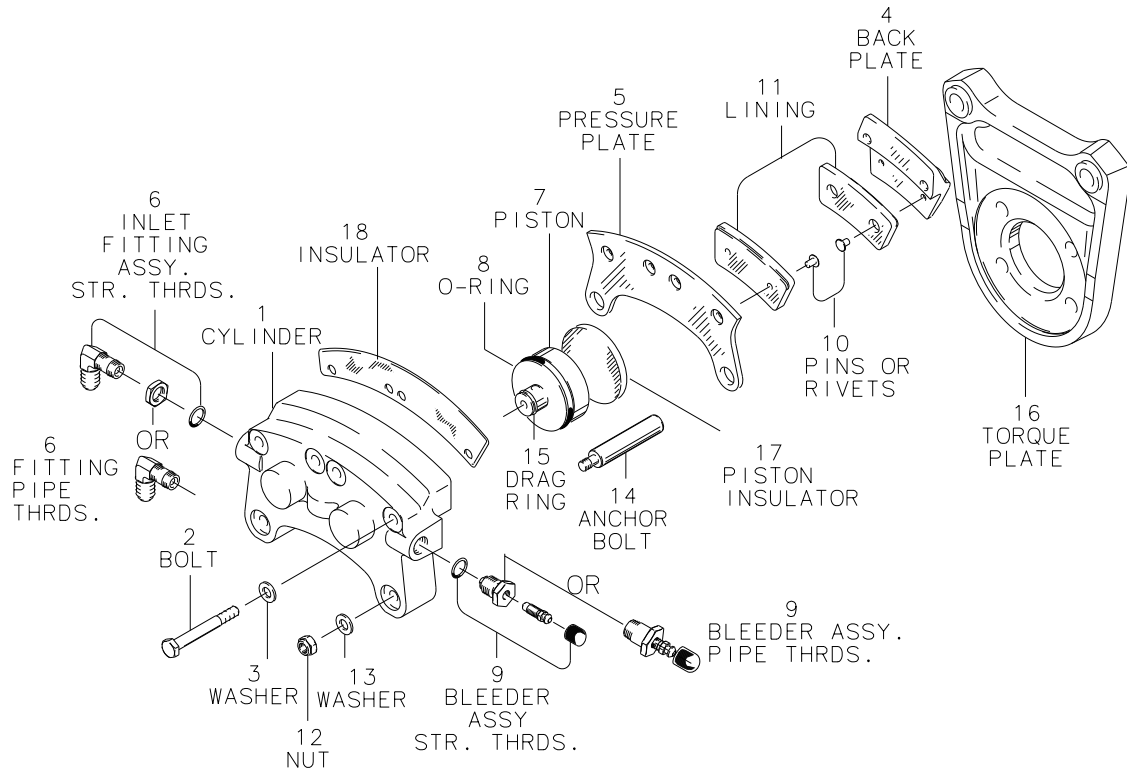

Figure 2 - Typical External Disc Brake Assembly

3. Wheel Assemblies

All aircraft wheels are designed and qualification tested in accordance with TSO C26 for a particular tire type and size matching the aircraft requirements. Operating a wheel assembly with unapproved tires, improper inflation pressures or subjected to loads in excess of its design is a violation of the wheel certification basis and is prohibited.

Description and operation of three different wheel assemblies is covered in the following text. The nose wheel assembly and the tail wheel assembly are sufficiently similar to consider together. The main wheel will be described separately. In each case, information is based on a typical wheel assembly. Specific illustrated parts breakdown for wheel assemblies may be found at [clevelandwheelandbrake.com](http://clevelandwheelandbrake.com)

**Description and Operation**

---

**CAUTION:** THE FELT GREASE SEALS ARE SHIPPED DRY. THEY MUST BE LUBRICATED TO PROVIDE PROTECTION AND LUBRICANT RETENTION FOR THE BEARINGS. IF THEY ARE NOT PROPERLY LUBRICATED THEN MOISTURE CAN SOAK PAST THE FELTS AND CONTACT THE BEARINGS WHICH CAN LEAD TO BEARING FAILURE. REFER TO PARAGRAPH 3.A AND 3.B BELOW.

**A. Nose and Tail Wheel Description**

Wheels are made from either aluminum castings, magnesium castings, or aluminum forgings. The wheel is of the divided type, incorporating inner wheel half (10) and outer wheel half (8), Ref. Figure 3, which are fastened together with tie bolts (7), washers (6), and nuts (5). An o-ring (9) fitted between the two wheel halves provides the air seal for wheels designed to operate with tubeless tires. The wheel rotates on two tapered roller bearings (4) which seat in bearing cups, shrink fitted into the hubs. Grease seals (2) and (3) provide protection and lubricant retention for the bearings. All new product shipped will have the bearings packed with the appropriate grease ([refer to Section 300 Off-Aircraft Maintenance, paragraph 3.A. Bearing Grease](#)). Hubcaps, when used, are secured to the outboard wheel half by a snap ring (1) or three attachment screws. Full wheel covers are fastened by three attachment screws.

**B. Main Wheel Description**

Wheels are made from either aluminum castings, magnesium castings, or aluminum forgings. The wheel is of the divided type, incorporating inner wheel half (10) and outer wheel half (8), Ref. Figure 4, which are fastened together with tie bolts (7), washers (6), and nuts (5). The brake disc (11) is attached to the wheel by the tie bolts. In a few designs, the brake disc bolts are threaded directly into inserts pressed into the back of the inboard wheel half. Wheels fall into two categories, tubeless and tube type. An o-ring (9) fitted between the two wheel halves provides the air seal for wheels designed to operate with tubeless tires. The wheel rotates on two tapered roller bearings (4) which seat in bearing cups in the hubs. Grease seals (2) and (3) provide protection and lubricant retention for the bearings. All new product shipped will have the bearings packed with the appropriate grease ([refer to Section 300 Off-Aircraft Maintenance, paragraph 3.A. Bearing Grease](#)). Hubcaps, when used, are secured to the outboard wheel half by a snap ring (1) or three attachment screws. Full wheel covers are fastened by three attachment screws.

**C. Wheel Operation**

The wheels, attached to the landing gear, support the tires and weight of the aircraft. The nose wheel provides a means of steering control, if so equipped. The main wheels transmit stopping forces from the brake to the ground.

**Description and Operation**

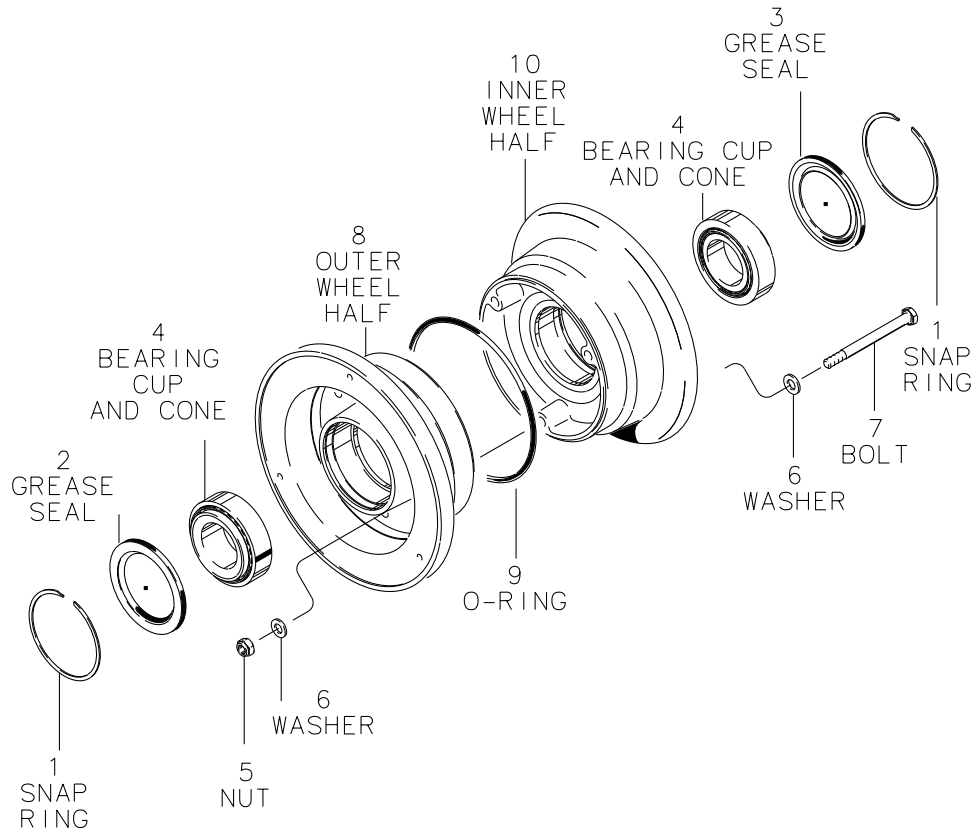

Figure 3 - Typical Nose/Tail Wheel Assembly

**Description and Operation**

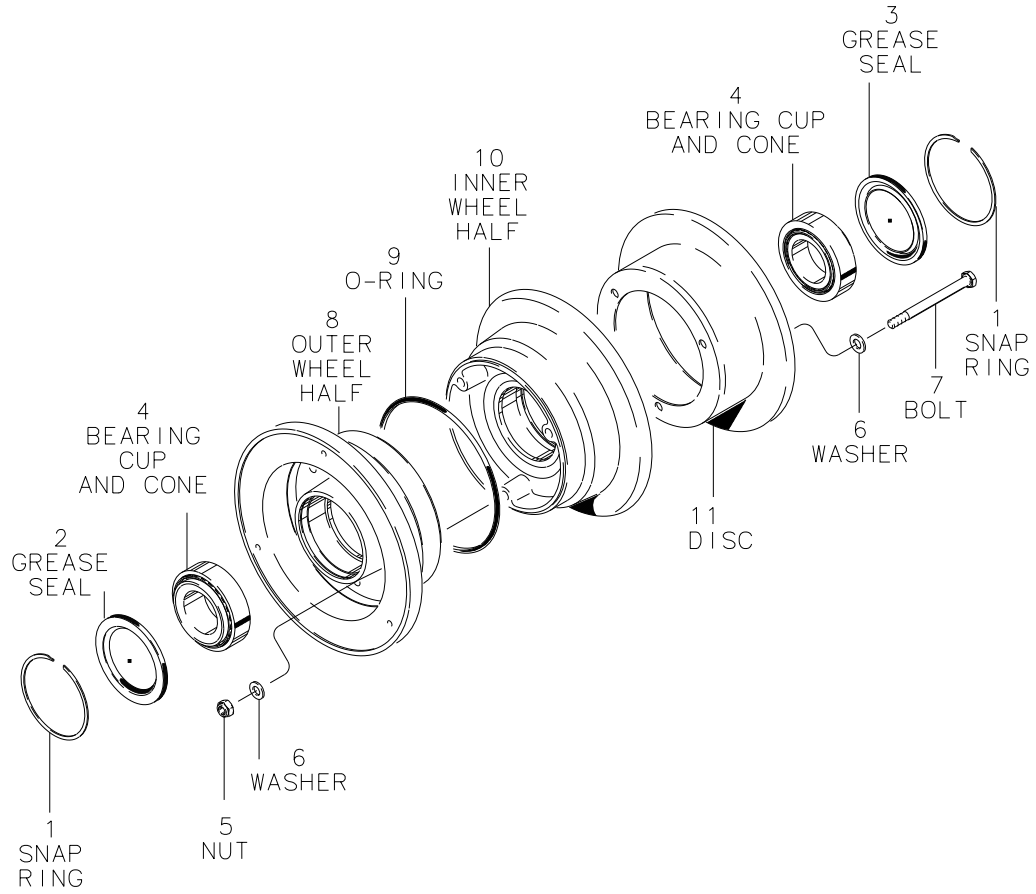

Figure 4 - Typical Main Wheel Assembly

**1. General**

This section provides information necessary to identify, diagnose, and correct potential problems which may occur with the wheel or brake assemblies.

**2. Brake Assembly Troubleshooting**

Refer to the troubleshooting chart in Table 101 for assistance in diagnosing brake related difficulties. When a correction has been identified for a particular problem, refer to the appropriate reference in either the ON-AIRCRAFT or OFF-AIRCRAFT MAINTENANCE sections of this manual, or if available, refer to individual wheel and brake maintenance manual for the specific aircraft application.

Table 101  
Brake Assembly Troubleshooting

TROUBLE	PROBABLE CAUSE	CORRECTION
1. Unable to obtain sufficient hydraulic brake pressure.  Excessive toe pedal travel; spongy pedal.	Air in hydraulic system.	Check for source, then bleed hydraulic system.
	Vent in master cylinder reservoir clogged.	Clean vent or overboard drain.
	Leak in system; brake, master cylinder, fittings, or lines.	Locate leak and repair.
	Defective master cylinder.	Replace or repair.
	Back plate bolts loose (not properly torqued), causing excessive brake deflection.	Torque bolts to proper value. See Torque chart in Appendix A.
	Excess bolt torque has caused back plate to crush cylinder, evidenced by depressions around bolt holes.	Replace cylinder and follow manufacturer's recommended torque values.
	Defective brake line (ballooning).	Replace.
	Improper adjustment of master cylinder rod length restricting the development of maximum stroke.	Adjust length per the aircraft maintenance manual.

Table 101 - Continued  
Brake Assembly Troubleshooting

TROUBLE	PROBABLE CAUSE	CORRECTION
2. Brake drag.	Piston cocked in cylinder, resulting in overheating brake and/or excessive lining wear.	Remove and repair cylinder or piston, or replace brake.
	Foreign matter wedged in brakes.	Locate and remove.
	Back pressure due to malfunction of master cylinder or parking valve.	Bleed hydraulic system and/or repair/replace master cylinder or parking valve.
	Water or ice in hydraulic system.	Flush and bleed hydraulic system (thaw ice first).
	Excessive bolt torque has caused back plate to crush cylinder, evidenced by depressions around bolt holes.	Replace cylinder and follow manufacturer's recommended torque value.
	Piston does not retract.	Bleed system and/or remove piston. Inspect for damage.
	Warped pressure plate.	Replace pressure plate or flatten to within 0.010 inch (0.254 mm).
	Rigid hydraulic line(s) prevents brake from floating freely. Flexible hydraulic lines are recommended.	Check free cylinder movement. Position cylinder and re-tighten fitting.
	Corroded anchor bolts and/or torque plate bushings.	Clean and lubricate or replace.
	Cocked anchor bolts and/or torque plate bushings.	Replace.
	Bent/cracked torque plate.	Replace.
	Warped brake disc - can be checked by laying a straightedge across disc face.	Replace and use caution during operation to prevent excessive energy input into brake.
	Out of position/stuck lining.	Repair/replace.
	Restriction in hydraulic line.	Isolate and remove restriction.
Lining not firmly seated flush against pressure/back plate.	Debur rivet hole on surface adjacent to lining.	

Table 101 - Continued  
Brake Assembly Troubleshooting

TROUBLE	PROBABLE CAUSE	CORRECTION
3. Rapid disc and lining wear.	Dragging brakes.	See Table 101, Trouble #2.
	Improper conditioning of brake linings.	See lining conditioning procedures, ON-AIRCRAFT MAINTENANCE PARA 2.B. (2)
	Excessive rusting, scoring, or pitting of brake disc	Clean or replace disc. Use factory chrome-plated disc where applicable.
	Excessive back plate deflection caused by bent bolts or over torquing bolts.	Check and replace bolts. Check torque per Appendix A.
	Incorrect lining and/or disc.	Replace with correct parts.
4. Brakes won't hold.	Contaminated lining.	Replace lining.
	Improper conditioning of brake linings.	See lining conditioning procedures, ON-AIRCRAFT MAINTENANCE para 2.B. (2).
	Lining worn below minimum wear limits.	Replace lining. Refer to Appendix A.
	Discs worn below minimum wear limits.	Replace discs. Refer to Appendix A.
	Insufficient hydraulic pressure.	See Table 101, TROUBLE #1
	Organic brake lining carburized (overheated).	Replace lining.
	Pressure plate contacting torque plate assembly.	Check for correct torque plate/wheel installation.
	New Lining installed with old disc, Lining not seated in wear track creating partial contact with disc.	Replace excessively worn disc.

3. Wheel Assembly Troubleshooting

Refer to the troubleshooting chart in Table 102 for assistance in diagnosing wheel related difficulties. When a correction has been identified for a particular problem, refer to the appropriate reference in either the ON-AIRCRAFT or OFF-AIRCRAFT MAINTENANCE sections of this manual, or if available refer to the specific wheel and brake maintenance manual for that equipment.

Table 102  
Wheel Assembly Troubleshooting

TROUBLE	PROBABLE CAUSE	CORRECTION
1. Cracked or distorted wheel or wheel half.  <b>CAUTION:</b> DO NOT ATTEMPT TO WELD OR REPAIR CRACKS IN WHEEL HALVES.	Hitting rocks or other hard objects during landing or takeoff.	Inspect wheel using Zyglo to determine condition. Replace wheel or wheel half.
	Use of sharp objects to break tire bead.	Replace wheel or wheel half.
	Landing with flat tire or abnormally hard landing.	Replace wheel or wheel half.
	Landing in crabbing position in crosswind causing excessive side force.	Replace wheel or wheel half.
	Normal fatigue failure when used beyond expected wheel life.	Replace wheel or wheel half.
2. Damaged bearing cone.	Misalignment of bearings.	Replace bearing cone being sure it is properly seated in bearing bore.
	Axle nut improperly torqued.	Replace and torque axle nut to aircraft manufacturer's specifications.
	Foreign matter in bearing grease.	Check grease seals for damage. Replace seals and be sure bearing grease is free from foreign matter.
	Lack of bearing grease.	Replace bearings and repack with grease.
3. Worn or damaged grease seals.	Normal wear or improper installation.	Replace grease seals.

**CAUTION:** RUNWAY ANTI-ICING FLUIDS AND CERTAIN DISINFECTANTS USED TO PREVENT THE SPREAD OF HOOF AND MOUTH DISEASE HAVE BEEN FOUND TO HAVE ADVERSE EFFECTS ON THE AIRCRAFT WHEEL AND BRAKE SYSTEM COMPONENTS. A HIGHER DEGREE OF PREVENTATIVE MAINTENANCE IS REQUIRED IN THOSE AREAS USING SUCH AGENTS.

## 1. General

This section covers maintenance which can be performed while the wheel and brake assemblies remain attached to the aircraft.

## 2. Brake Assembly On-Aircraft Inspection and Maintenance

On-aircraft inspection and maintenance of brake assemblies is essentially limited to inspection of the assembly and replacement of the linings.

### A. Brake Inspection

- (1) Visually inspect the brakes for corrosion, cracks, or other visible damage. Check inlet fitting bosses and anchor bolt lugs for cracks. Check inlet flares on aircraft side of rigid hydraulic tubing for fatigue cracks.
- (2) Check back plate attachment bolts to ensure they are properly torqued and have not worked loose. Gaps between the back plate and cylinder would be evidence of this.
- (3) Check fit of brake cylinder anchor bolts in torque plate bushings for sloppiness. This can be accomplished by grasping the cylinder and moving it; slight movement is normal. Excessive movement is cause for removal and detailed inspection.
- (4) Linings should be visually checked for extreme chipping on the edges. Lining worn to a minimum thickness of 0.100 inch (2.54 mm) must be replaced. ([Ref. Appendix A for more details.](#))
- (5) Visually check torque plate for corrosion, cracks, loose anchor bolt bushings, or other visible damage. Anchor bolt bushings must be flat against torque plate surface.
- (6) Check for any brake fluid leaks. Organic linings which have been contaminated with fluid should be replaced.

### B. Corrective Maintenance of Brakes

On-aircraft corrective maintenance of the brake assembly involves replacement of the linings. This maintenance procedure may be accomplished without raising the aircraft or removing the main wheel.

## (1) Replacement of Metallic Brake Linings

The minimum wear thickness for replacement of metallic linings is 0.100 inch (2.54 mm). [Ref. Appendix A, Figure A1](#). The metallic lining is a sintered metal composition and is attached by torque pins which fit into the back surface (steel carrier plate) of the lining. The holes for the pins are not visible on the lining surface unless the lining is worn beyond its wear limit. [Ref. Figure 201](#).

## (a) Removal of Linings from Calipers

**WARNING: BLOCK WHEELS AND ENSURE THAT PARKING BRAKE IS IN OFF POSITION.**

- 1 Remove back plate attaching bolts and washers, and remove back plates, shims, and insulators (if applicable).
- 2 Carefully slide brake caliper out of torque plate bushing.
- 3 Slide pressure plate assembly (lining carrier) off anchor bolts.

## (b) Inspection of Caliper and Torque Plate Assembly

Inspect the caliper for corrosion, bent anchor bolts, cracks around bolts, cracks around anchor bolt lugs and inlet fittings, and other visible damage. Inspect the torque plate assemblies for corrosion around anchor bolt bushings and excessive wear in bushings.

## (c) Replacement of Metallic Linings

- 1 On models so equipped, remove center retention rivet, by drilling out with a 1/8-inch drill.
- 2 Pry off old lining using a screwdriver.
- 3 Clean pressure plate and back plate surfaces of dirt, grease, etc. before installing new linings.
- 4 Inspect pressure plate and back plates for excessive warping. Straighten pressure plate to less than 0.010 inch (0.254 mm) flatness, as shown in [Figure 203](#).
- 5 Check lining attachment pins for mushroomed heads or other visible damage. Damaged attachment pins must be replaced by carefully drilling out the pins.
  - a Install replacement pin in holes in pressure plate or back plate with tail of pin toward the counterbored side of part.

- b Hole locations in pressure plates / back plates should allow installation of lining after pin upset.
  - c Place pins and pressure plate or back plate on a flat metal surface.
  - d Using appropriate rivet tools, install pins on pressure plate or back plate.
  - e Check to be sure pins are tight and movement free with no distortion of parts.
  - f [Refer to Figure 204](#) for rivet / pin installation acceptance criteria.
- 6 Apply a light film of spray adhesive to steel carrier plate of lining and install lining segment onto pins. Fit of counterbores of the lining segments with pins can be a clearance to press fit depending on lining segment part numbers. Check to ensure the steel carrier plate is tight against the pressure plates / back plates. Ref. Figure 201.
- NOTE:** The adhesive is used to maintain position of lining until brake is assembled onto disc, and will be burned off in the first few stops. Lining will remain in place on assembly trapped between the brake disc and pressure / back plates.
- 7 On design so equipped, install the center retention rivet as shown in [Figure 202](#).

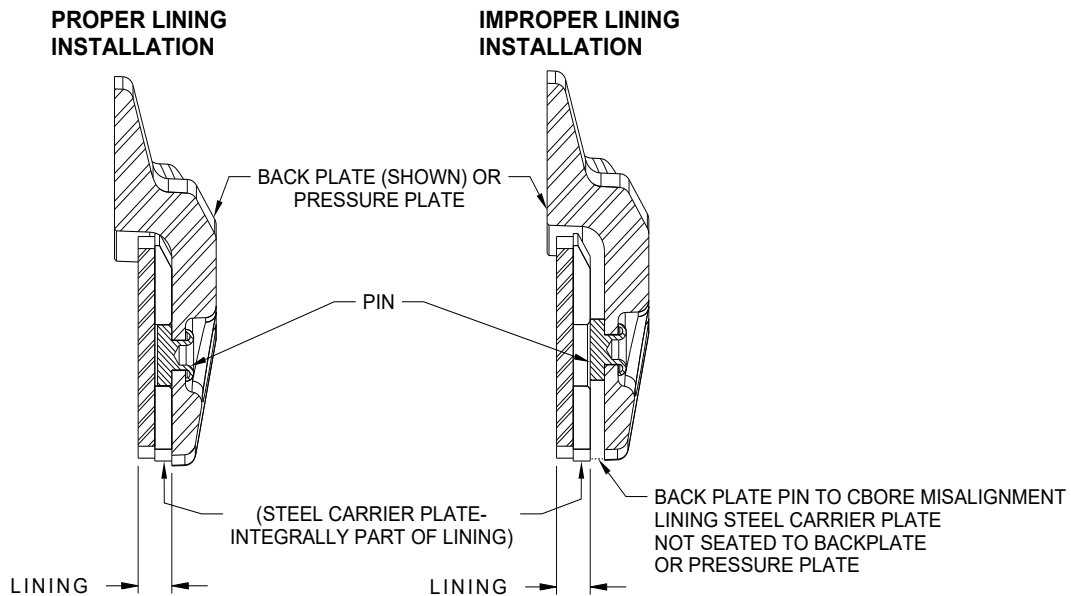

Figure 201 - Pin Installation, Metallic Lining

## (d) Reassembly of Metallic Linings to Caliper

- 1 Carefully wipe dirt, grease, etc. from cylinder, pressure plate, and portions of piston extending beyond cylinder face, and push piston back into cylinder.
- 2 Lubricate the anchor bolts with a dry film lubricant ([Appendix B, Section B3](#)) specified for your climate environment: amphibious/extremely wet or non-amphibious. **DO NOT USE GREASE OR OIL.** These materials will attract dirt and enhance the wear of the anchor pins.
- 3 Slide pressure plate with new lining over anchor bolts and install brake caliper into torque plate.
- 4 Install back plate attachment bolts and washers in brake caliper.
- 5 Install insulator shims (typically used with metallic lining) and spacers as applicable.
- 6 Slide back plates between brake disc and wheel/tire and install back plate attachment bolts and washers into back plates.
- 7 Torque brake assembly back plate tie bolts to values listed in [Appendix A](#). Two different types of back plate tie bolts are used. The patch lock bolt (nylon material embedded in threaded end) will require replacement after 6 to 8 installations or whenever the bolts can be run in past the locking feature by use of fingers only. Bolts with drilled heads require safety wire after torquing.
- 8 Actuate brake pedal prior to towing or taxiing. Check lining for proper alignment and engagement onto pins. Lining steel carrier plate should be seated on back plate or pressure plate. [Ref. Figure 201](#)

**NOTE:** Actuating the brake pedal will ensure pistons are extended prior to towing or taxiing. This will minimize running clearance for proper placement of linings.

## (2) Replacement of Organic Brake Linings

The organic brake lining is identified by its semi hard composition and rivets used to attach the lining to the pressure plate or back plate. The rivet holes are visible on the lining. Non asbestos, lead free lining material is also being used as a replacement for the old style organic lining and is removed and installed in the same manner as the organic lining. [Ref. Figure 202. Appendix C](#) provides a brake assembly / lining cross-reference information.

## (a) Removal of Linings from Calipers

**WARNING: BLOCK WHEELS AND ENSURE THAT PARKING BRAKE IS IN OFF POSITION.**

- 1 Remove back plate attaching bolts and washers, and remove back plates, shims, and insulators (if applicable).
- 2 Carefully slide brake caliper out of torque plate bushing.
- 3 Slide pressure plate assembly (lining carrier) off anchor bolts.

## (b) Inspection of Caliper and Torque Plate Assembly

Inspect the caliper for corrosion, bent anchor bolts, cracks around bolts, cracks around anchor bolt lugs and inlet fittings, and other visible damage. Inspect the torque plate assemblies for corrosion around anchor bolt bushings and excessive wear in bushings.

## (c) Replacement of Organic Linings

- 1 Old organic lining may be removed by using a small drift pin or carefully drilling out the rivets with a 1/8-inch diameter drill. Use care to prevent elongating the rivet holes. Deburr the surface adjacent to the lining to allow lining to set flush.
- 2 Clean pressure plate and back plate surfaces of dirt, grease, etc. before installing new linings.
- 3 Inspect pressure plate and back plate for excessive corrosion, visible damage, or excessive warping. Pressure plate should not be used if warped in excess of 0.010 inch (0.254 mm) flatness, by using draw flattening or straightening techniques. [Ref. Figure 203](#). Excessive warping can result in brake drag, especially when new disc and linings are installed.
- 4 Align new factory authorized replacement lining segments on pressure plate/back plates and install rivets of corresponding part number, using appropriate riveting tools.
- 5 Check to be sure lining is tight and movement free with no distortion of parts.
- 6 With tubular rivets, splits may result from the clinching operation. [Refer to rivet sketch, Figure 204](#), for acceptance criteria.

## (d) Reassembly of Organic Linings to Caliper

- 1 Carefully wipe dirt, grease, etc. from cylinder, pressure plate, and portions of piston extending beyond cylinder face, and push piston back into cylinder.
- 2 Lubricate the anchor bolts with a dry film lubricant ([Appendix B, Section B3](#)) specified for your climate environment: amphibious/extremely wet or non-amphibious. **DO NOT USE GREASE OR OIL.** These materials will attract dirt and enhance the wear of the anchor pins.
- 3 Slide pressure plate with new lining over anchor bolts and install brake caliper into torque plate.
- 4 Install back plate attachment bolts and washers in brake caliper.
- 5 Install insulator shims (typically used with metallic lining) and spacers as applicable.
- 6 Slide back plates between brake disc and wheel/tire and install back plate attachment bolts and washers into back plates.
- 7 Torque brake assembly back plate tie bolts to values listed in [Appendix A](#). Two different types of back plate tie bolts are used. The patch lock bolt (nylon material embedded in threaded end) will require replacement after 6 to 8 installations or whenever the bolts can be run in past the locking feature by use of fingers only. Bolts with drilled heads require safety wire after torquing.

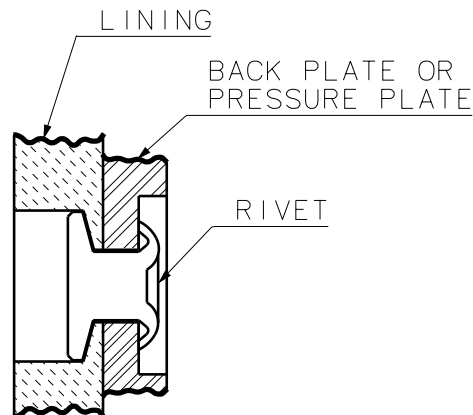

Figure 202 - Rivet Installation, Organic Lining

(3) Pressure Plate Straightening Setup Technique

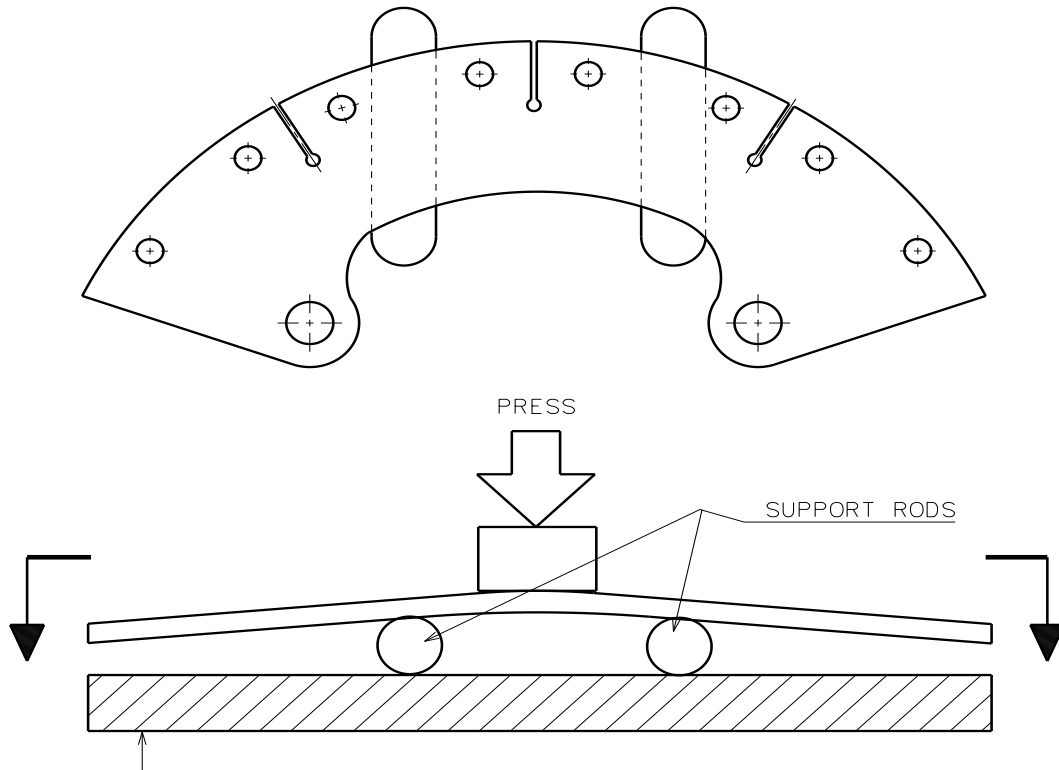

Figure 203 - Pressure Plate Straightening

(4) Rivet / Pin Installation Acceptance Criteria for Metallic and Organic Linings

- 1 The split shall not occur inside the crest of the clenched surface.
- 2 No more than two splits shall occur in a 90° area.
- 3 A total of no more than three splits shall be allowed.

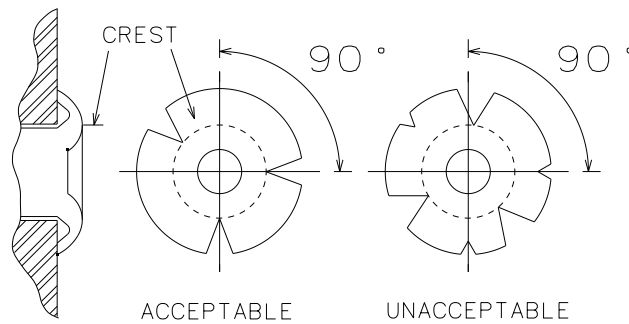

Figure 204 - Rivet / Pin Installation Acceptance Criteria For Metallic and Organic Linings

- (5) Installation of 066-00504 Lining to Brake Shoe
- a Using an 1/8 inch drill bit, drill out six rivets and remove the old lining from brake shoe.
  - b Clean and deburr brake shoe as needed.
  - c Place new lining on brake shoe, centered as closely as possible onto lining mount surface. Using a scribe, mark centerline location of 6 holes to be drilled in new lining.
  - d Drill and counterbore lining as shown in Figure 205 (6 places).

Mount new linings onto shoe with 6 rivets, P/N 105-00300; rivet head to seat to bottom of lining counterbore.

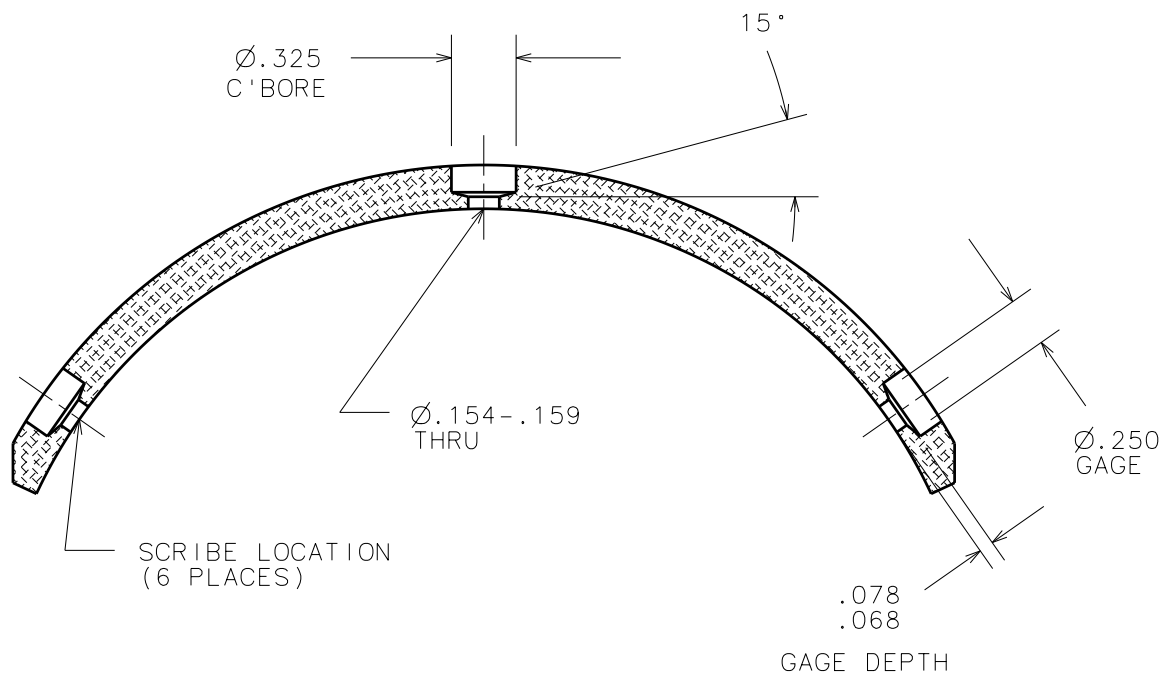

Figure 205 - Installation of 066-00504 Lining to Brake Shoe

**(6) Lining Conditioning Procedures**

When new linings have been installed, it is important to condition them properly to obtain the service life designed into them. The metallic and organic linings are not conditioned in the same manner because they have different operating characteristics. Separate conditioning procedures are given for metallic and organic linings.

**ORGANIC LININGS**

1. Taxi aircraft for 1500 feet with engine at 1700 rpm applying brake pedal force as needed to develop a 5-10 mph taxi speed.
2. Allow the brakes to cool for 10 to 15 minutes.
3. Apply brakes and check for restraint at high static throttle. If brakes hold, conditioning is complete.
4. If brakes cannot hold aircraft during static run up, allow brakes to completely cool, and repeat steps 1 through 3.

**METALLIC LININGS**

1. Perform two (2) consecutive full stop braking applications from 30 to 35 knots. Do not allow the brake discs to cool substantially between the stops.
2. Allow the brakes to cool for 10-15 minutes.
3. Apply brakes and check for restraint at high static throttle. If brakes hold, conditioning is complete.
4. If brakes cannot hold aircraft during static run-up, allow brakes to completely cool, and repeat steps 1 through 3.

**CAUTION:** DUE TO THE EFFICIENCY OF THESE BRAKES, EXTREMELY HARD BRAKING ON AIRCRAFT WITH TAIL WHEELS COULD RESULT IN LIFTING THE TAIL FROM THE GROUND.

This conditioning procedure will wear off high spots and generate sufficient heat to create a thin layer of glazed material at the lining friction surface. Normal brake usage should generate enough heat to maintain the glaze throughout the life of the lining.

Properly conditioned linings will provide many hours of maintenance free service. A visual inspection of the brake disc will indicate the lining condition. A smooth surface, one without grooves, indicates the linings are properly glazed. If the disc is rough (grooved), the linings must be reglazed. The conditioning procedure should be performed whenever the rough disc condition is observed. Light use, such as in taxiing, will cause the glaze to be worn rapidly.

### 3. Wheel Assembly On-Aircraft Inspection and Maintenance

On-aircraft maintenance of wheel assemblies is limited to inspection of wheel assemblies. Inspections of the nose and trail wheels and of the main wheel are treated separately as follows.

#### A. Nose and Tail Wheel Inspection

Perform on-aircraft inspection as follows:

- (1) Visually inspect the wheels for corrosion, cracks, or other visible damage.
- (2) Check wheel nuts to be sure they are properly installed and have not worked loose. Bolt threads should be flush to 1.5 threads extending beyond the nut.

#### B. Main Wheel Inspection

Perform on-aircraft inspection as follows:

- (1) Visually inspect the wheels for corrosion, cracks, or other visible damage.
- (2) Check wheel nuts to be sure they are properly installed and have not worked loose. Bolt threads should be flush to 1-1/2 threads extending beyond the nut. Nuts should be on the side of wheel opposite the brake disc (outboard side of wheel), except in those cases where spline nuts and bolts are used to secure wheel halves.

**NOTE:** Brake Disc cracks are not allowed unless covered by a PRM (Product Reference Memo) or SB (Service Bulletin) issued specifically for a brake disc.

- (3) Inspect the brake disc for rust, excessive grooves, large cracks, or other visible damage. Refer to [Appendix A](#).

### 4. Tire On-Aircraft Inspection and Maintenance

On-aircraft maintenance of tires is limited to inspection and air pressure maintenance.

#### A. Tire Inspection

- (1) Visually inspect tires for cuts, flat spots, and tread or sidewall damage.
- (2) Check inflation pressure. Proper inflation will provide maximum tire and wheel life.
  - (a) Pressure should be checked daily, when tires are cool.
  - (b) Tubeless tires have an allowable 5% pressure loss in any 24-hour period.
- (3) Refer to tire manufacturer's service and maintenance manuals for recommended servicing procedures.

## 1. General

The following maintenance to brake assemblies and wheel assemblies is intended to be performed while these assemblies are off the aircraft.

## 2. Brake Assembly Off-Aircraft Maintenance

This section provides complete repair and refinishing instructions for the brake assembly. When servicing the brake assembly, careful handling of the brake components will assure optimum service life and trouble free operation.

**CAUTION:** A PRESSURE TEST [[PARAGRAPH 2.D. \(5\)](#)] IS REQUIRED WHENEVER THE FOLLOWING OCCURS:

- ANY REPAIR TO THE CYLINDER PRESSURE CHAMBER OR PISTON.
- ANY TIME A PISTON OR O-RING IS REMOVED WHICH CAN CAUSE DAMAGE TO THE O-RING; OR A NEW O-RING IS INSTALLED WHICH MAY UNKNOWINGLY BE DEFECTIVE.

THE BRAKE CYLINDER AND TORQUE PLATE SHOULD BE PROPERLY MAINTAINED TO PROTECT THE PAINT AND SURFACE FINISHES; EXPOSED ALUMINUM OR MAGNESIUM IS SUSCEPTIBLE TO CORROSION. NICKS, SCRATCHES, AND OTHER DAMAGE CAUSED BY IMPROPER HANDLING OF BRAKE PARTS DURING MAINTENANCE INVITE CORROSION, WHICH IF UNATTENDED, COULD LEAD TO FATIGUE CRACKS AND BRAKE FAILURE.

### A. Removal From Aircraft

**NOTE:** Wheel removal is not necessary unless brake torque plate is to be removed.

The following procedure describes how to remove the brake assembly from the main wheel.

**WARNING:** ENSURE PARKING BRAKE IS IN OFF POSITION AND WHEELS ARE BLOCKED.

- (1) Remove and cap hydraulic line attached to brake. Cap brake inlet fitting.
- (2) Remove back plate tie bolts and washers, and remove back plate.
- (3) Carefully slide brake cylinder out of torque plate.
- (4) If torque plate removal is required, remove wheel/tire per wheel removal instructions in [paragraph 3. Wheel Assembly Off-Aircraft Maintenance](#).

**SAFETY WARNING** : **DEFLATE TIRE IMMEDIATELY AFTER JACKING AIRCRAFT AND BEFORE AXLE NUT IS LOOSENED. FAILURE TO DEFLATE TIRE BEFORE WHEEL REMOVAL COULD RESULT IN SEVERE PERSONAL INJURY.**

- (5) Remove torque plate attachment bolts, nuts, and washers. Note the torque plate mounting rotational orientation for reinstallation.
- (6) Remove torque plate.

## B. Brake Disassembly

### (1) Disassembly Procedures

The following disassembly procedures for the removed brake assembly also apply to dual caliper brakes. Disassembly should be performed only to the level required to effect necessary repairs. Refer to [Figure 2, DESCRIPTION AND OPERATION section](#) for a general illustration, or [clevelandwheelandbrake.com](http://clevelandwheelandbrake.com) for the specific illustration of the unit being disassembled.

**CAUTION:** DISASSEMBLE BRAKE ON A CLEAN, CUSHIONED, FLAT SURFACE, BEING CAREFUL NOT TO NICK, SCRATCH, OR GOUGE BRAKE PARTS.

**NOTE:** Inspect parts in the dirty condition, as removed, for sources of leakage, damage, corrosion, and moisture in brake fluid.

- (a) Separate assembled cylinder (1) and torque plate (16). Brake assemblies that use metallic lining will also incorporate a thermal insulator shim (18) located between the back plate (4) and cylinder (1), and piston insulator (17), pressed into piston pocket, isolating piston (7), and pressure plate (5).
- (b) Remove back plate attachment bolts (2) and washers (3). Separate cylinder (1) and back plate (4).
- (c) Remove pressure plate (5) by sliding over anchor pins (14).
- (d) Remove inlet fitting.
- (e) On brakes so equipped, remove external retract mechanism from back of caliper. Note position of components for reassembly purposes.

**SAFETY WARNING** : **USE CAUTION IN BLOWING PISTONS OUT OF CYLINDER WITH AIR, AS PISTONS COULD FLY OUT AT HIGH VELOCITY. IT IS SUGGESTED THAT THE CYLINDER BE TURNED OVER SO THAT PISTONS FACE WORKING SURFACE. USE A RAG TO CUSHION PISTON CONTACT WITH SURFACE TO PREVENT PISTON DAMAGE. SAFETY GLASSES SHOULD BE WORN TO PROTECT EYES AND PREVENT DIRT OR BRAKE FLUID FROM ENTERING EYES.**

**DEATH OR SERIOUS INJURY COULD OCCUR IF COMPRESSED AIR IS DIRECTED AGAINST THE SKIN. MAXIMUM PRESSURE SHALL NOT EXCEED 20 PSI (138 kPa). WHEN WORKING WITH COMPRESSED AIR ALWAYS USE CHIP GUARDS, EYE PROTECTION, AND OTHER PERSONAL PROTECTIVE EQUIPMENT.**

- (f) Remove pistons (7) by injecting air into the ports (15 to 20 psi) [103 to 138 kPa] maximum pressure.

**NOTE:** Some pistons are equipped with a friction spring (drag ring) on the piston tail. It is recommended that this ring not be removed unless it is damaged or corroded. Ref. Figure 301.

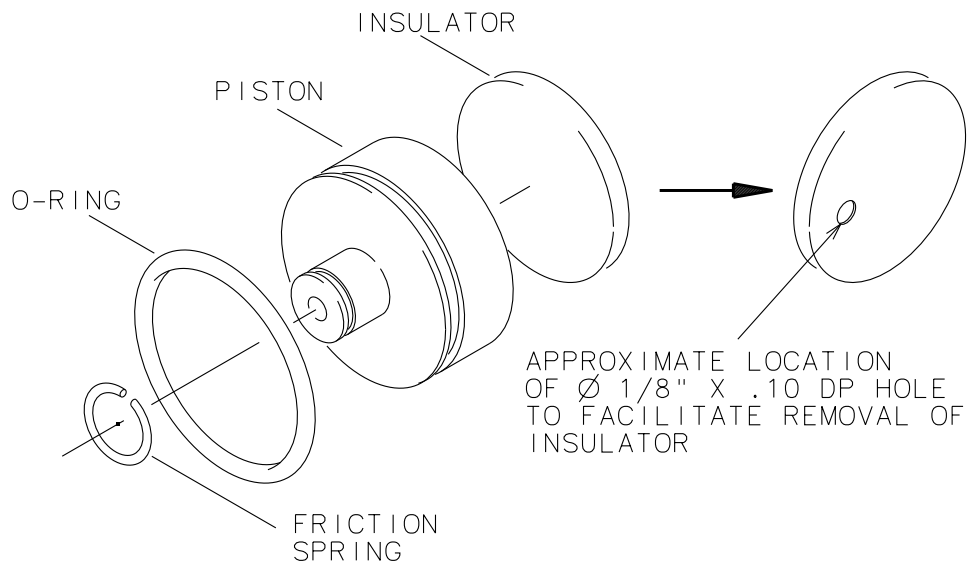

Figure 301 - External Piston Guide

- (g) Remove o-rings (8) from either pistons or cylinder. It is recommended that o-rings be replaced at reassembly. However, if necessary, o-rings may be reused if not damaged, cut, or deteriorated.

**CAUTION:** CARE SHOULD BE USED IN HANDLING O-RINGS TO PREVENT DAMAGE.

- (h) If possible, it is always best to remove o-rings without the use of tools. This may be accomplished as follows:

Securely holding piston in one hand, using opposite hand, form a “V” with thumb and index finger and push directly against o-ring to extrude it away from the piston groove on opposite side of piston. Push until outside diameter of the piston matches the natural radius on your hand between the index finger and thumb. Piston should now be held firmly in place with this hand. Grip extruded o-ring on opposite side and remove from piston.

If this method is unsuccessful use Cleveland’s O-ring Extractor Kit, P/N 199-18, for o-ring removal.

- (i) A piston to pressure plate insulator disc is used on brake assemblies with metallic linings. Constant heat and pressure will compress the insulator over time. Replace the insulator when it is flush with the head of the piston. Drill 1/8” diameter hole directly into insulator approximately .10 inches deep, slightly off center, but not close to outside diameter of piston. Use small screwdriver working through the 1/8” diameter hole, lift and pry off insulator disc.
- (j) Remove bleeder fitting (9), rubber caps, and o-rings from cylinder.

**NOTE:** Some designs have an internal piston guide (inside of the piston) attached to the cylinder by a bolt, washer, and Stat-O-Seal. It is recommended that this unit not be removed unless it is damaged or corroded. [Ref. Figure 302](#). If Stat-O-Seal is removed, replace it. Do not reuse as it will not re-seal properly.

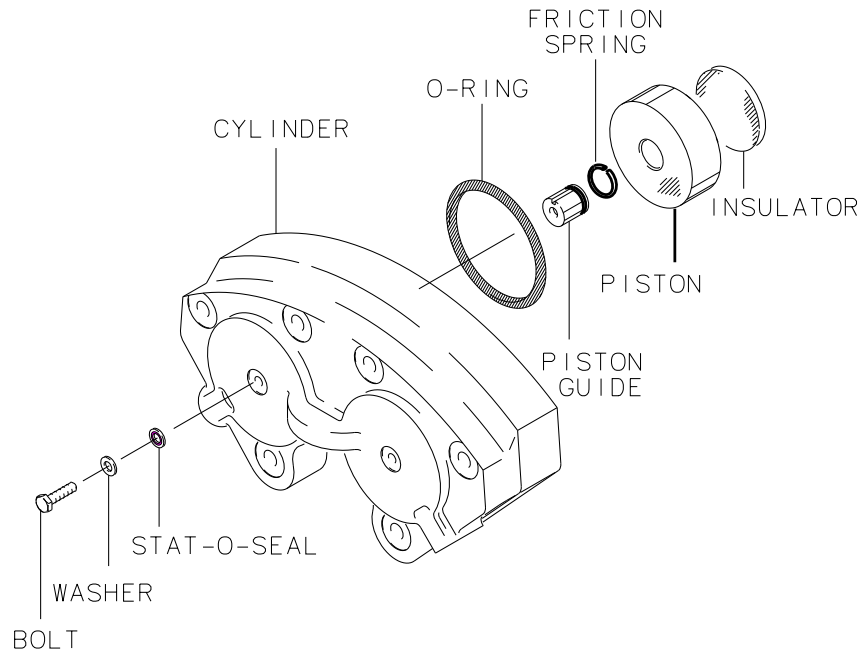

Figure 302 - Internal Piston Guide

## (2) Lining Removal

Removal of the linings is unique for both metallic and organic linings. The following text explains how to identify whether a lining is metallic or organic and gives step-by-step removal procedures. The minimum wear thickness on metallic and organic linings is 0.100 inch (2.54 mm) thickness. [Ref. Appendix A, Figure A1](#). A brake assembly / lining cross-reference list is located in [Appendix C](#).

## (a) Removal of Metallic Linings

The metallic lining is a hard composition and is attached by pins which press fit into the back surface (steel carrier plate) of the lining. [Ref. Figure 201](#). The holes for the pins are not visible on the lining surface unless the lining is worn beyond its wear limit. Remove as follows:

**NOTE:** On some designs with a wide face lining, a rivet is also used for retention.

- 1 Pry lining off pressure plate/back plate with a thin screwdriver.
- 2 Damaged attachment pins may be removed by carefully drilling out the pin.

## (b) Removal of Organic Linings

The organic brake lining is identified by its semi hard composition and rivets used to attach the lining to the pressure plate. The rivet holes are visible on the lining. Remove as follows:

- 1 Being careful not to enlarge holes in pressure plate/back plate, drill out rivets attaching lining with a 1/8-inch diameter drill.
- 2 Separate lining from pressure plate/back plate.

## (3) Anchor Bolt Removal

**NOTE:** The anchor bolt is a press fit into the cylinder body and should only be removed if any of the following conditions are observed.

- Scratches, nicks, pitting, corrosion, or evidence of overheating
- Spinning when turned by hand
- Movement when force is applied by hand
- Elongated brake cylinder bore or evidence of movement in bore
- A gap between the anchor bolt and cylinder housing (inspected visually or under magnification)

**NOTE:** Please be aware of potential degradation of the press fit with repeated removals and replacements of the anchor bolts.

- (a) Remove anchor bolt attachment nuts (12) and washers (13). The anchor bolts should be removed by using an arbor press. Ref. Figure 303.
- (b) Place on a clean, flat surface to prevent damage and nicks to soft cylinder material.

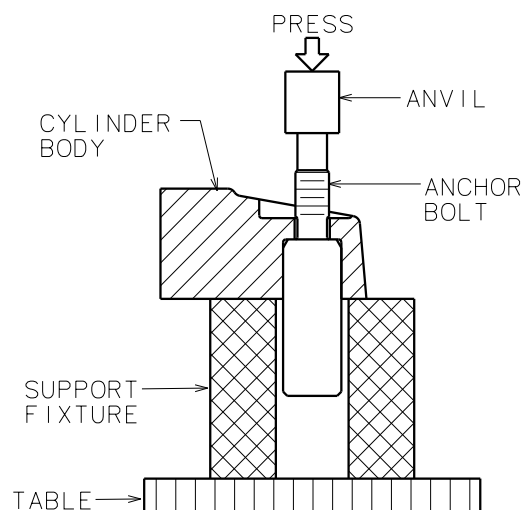

Figure 303 - Anchor Bolt Removal

## C. Inspection

**NOTE:** Parts of the inspection procedure require removal of paint. [Refer to Section 4](#) for information concerning paint removal and refinishing of these parts.

- (1) Visually inspect cylinder for cracks, nicks, corrosion, or other damage. Cracks in the lug area around the anchor bolts or the port bosses are cause for replacement of the cylinder. Check for dimpled areas around back plate bolt holes. Maximum allowable depression is 0.005 inch (0.127 mm). Ref. Figure 304.
- (2) Inspect the fitting ports and piston bores for contamination. Light scratches or nicks in the piston bores, pilot bores, or on the chamfered surfaces within these bores may be hand polished with 600 grit emery. Power tools are not recommended as they may remove excessive amounts of material. Thoroughly clean part.

**NOTE:** Heavy scratches, nicks and burrs in the pilot bore area can prevent the pistons from properly retracting, resulting in brake drag.

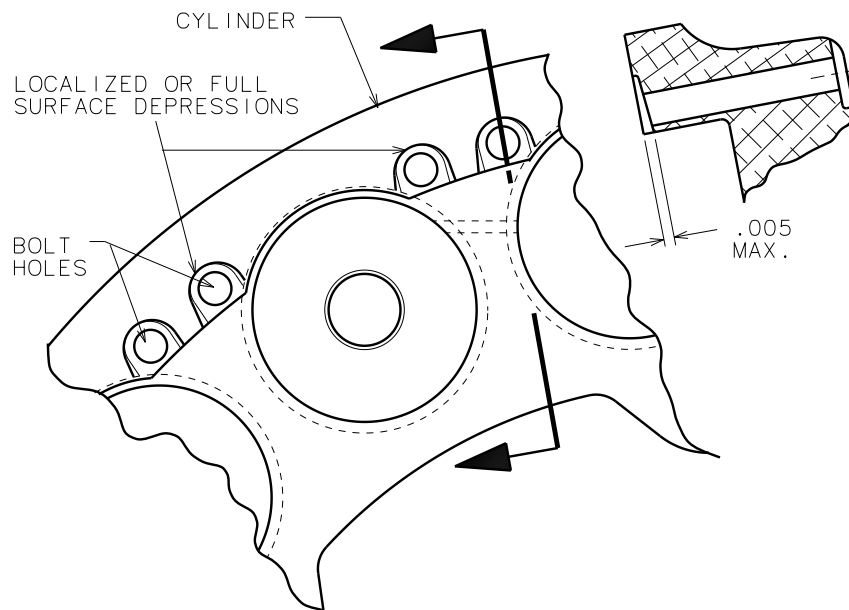

Figure 304 - Cylinder To Back Plate Surface Inspection

- (3) Replace o-rings with o-rings of corresponding part numbers. If necessary, o-rings may be reused in the same position from which they were removed if not damaged. Inspect o-rings for cuts, nicks, distortion, or excessive wear. Check to be sure o-ring has not become brittle. [Refer to o-ring removal procedure in paragraph 2B \(1\)\(h\).](#)

- (4) Inspect pistons for nicks or burrs. Check the piston tail for damage, and replace piston if damaged beyond repair. Remove nicks or burrs by hand polishing with 600 grit emery paper. Thoroughly clean part.
- (5) Inspect brake lining for edge chipping and surface deterioration. Normal use will result in some edge chipping. A maximum of 10 percent surface loss is acceptable. Minor accumulation of metal chips in lining is normal and not detrimental. Elongated rivet or pin holes is cause for replacement. Smearing of lining material on the brake disc which exceeds 30 percent of the surface is cause for replacement.

**NOTE:** Any fluid contamination of organic brake lining is cause for replacement.

- (6) Inspect back plates and pressure plate for cracks, nicks, rust, warping, stripped threads, elongated holes, or other damage. Small nicks and light corrosion may be hand finished using emery of 600 grit sandpaper. Any area from which the protective coating is removed should be thoroughly cleaned and treated per instructions in [Chapter 4](#) of this section.

**NOTE:** Slightly warped pressure plates can be cold straightened, [Ref. Figure 203](#). When laid on a flat surface, flatness should be within 0.010 inch (0.254 mm). Warped pressure plates can cause brake drag.

- (7) Inspect anchor bolt bushings in torque plate for internal corrosion or contamination. If present, clean with emery and apply a light coat of dry film lubricant ([Appendix B, Section B3](#) for your climate environment). **DO NOT USE GREASE OR OIL.** Exercise care in removing corrosion from torque plate bushings to prevent material removal.

**NOTE:** Cast torque plates have bushings press fit into the casting. The unit must be replaced as an assembly. Individual components are not available.

- (8) Check for steps in bushing holes, which indicate severe cocking of the cylinder anchor bolts in the torque plate. Bushing damage is cause for torque plate replacement.

**NOTE:** Bushings installed in cast torque plates must have the lip of the bushing seated flat against the machined torque plate surface.

- (9) Check the anchor bolt bushings and mounting bolt hole areas for elongation or cracks. Badly elongated holes or cracked torque plates should be replaced with a new torque plate of corresponding part number. Minor corrosion on the torque plates should be removed with 600 grit emery.

- (10) Inspect bolts for cracks, bending, thread damage, or excessive corrosion. Bolts with evidence of any of these should be replaced with bolts of corresponding part numbers, as specified in the Cleveland parts list found at [clevelandwheelandbrake.com](http://clevelandwheelandbrake.com). Two different types of back plate tie bolts are used. The patch lock bolt (nylon material embedded in threaded end) will require replacement after 6 to 8 installations or whenever the bolts can be run in past the locking feature by use of fingers only. Bolts with drilled heads require safety wire after torquing.

#### D. Brake Reassembly

**CAUTION:** ASSEMBLE BRAKE ON A CLEAN FLAT SURFACE, BEING CAREFUL NOT TO NICK, SCRATCH, OR DAMAGE PROTECTIVE FINISH OF BRAKE PARTS.

##### (1) Reassembly Procedures

- (a) Thoroughly clean parts before assembling.
- (b) If anchor bolts were removed, the following items shall be completed prior to installation.
- Remove any surface corrosion from the anchor bolt hole diameter with a fine emery cloth or a scotch brite pad. If corrosion has caused pitting, the brake cylinder should be replaced.
  - Measure in any direction the anchor bolt hole diameter. The anchor bolt hole diameter shall not be larger than the diameter of the anchor bolt (line to line press fit is the minimum criteria).

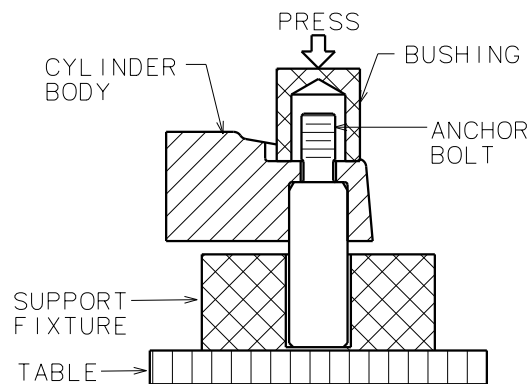

Figure 305 - Anchor Bolt Installation

- 1 Install anchor bolts using an arbor press and a holding fixture. Refer to Figure 305. Ensure that bolt is **perpendicular** to the cylinder and **parallel** to one another.
- 2 The press fit should be felt immediately when attempting to install the new bolt.
- 3 Install washers and nuts. Dry torque nuts to 90 inch-pounds (7.9 Nm). The torque to overcome the locking feature of the nut must be added to the above torque level to obtain the true torque.

(2) Installation of Pistons

Installation of pistons with an internal guide is the same as for other pistons. Care must be taken to ensure that no damage to parts occurs during installation. If considerable effort is required, remove piston and inspect bore and pilot bore area for damage. If bore is damaged, check the corresponding area of piston for damage.

- (a) Place piston in bore and rotate to seat friction spring (if applicable), and ensure that piston and o-ring are in proper alignment. Press piston into bore by hand. Tap the piston squarely with a wooden or plastic mallet (if required) while rotating piston.

(3) Lining Installation

[Refer to ON-AIRCRAFT MAINTENANCE Section 200](#) for detailed lining instructions.

(4) Further Reassembly of Brake Components

The remaining components of the disassembled brake unit shall be reassembled as follows:

- (a) Install inlet fitting, bleeder fitting, rubber caps, and O-rings, if applicable. A majority of the inlet fittings used on Cleveland brakes are pipe threads. Care should be exercised to prevent over tightening which could result in cracking of the cylinder casting. Install pipe thread fittings as follows.

**CAUTION:** NEVER BACK OFF (LOOSEN) PIPE THREADED FITTINGS TO ACHIEVE ALIGNMENT.

- 1 Inspect and clean each fitting to remove any oil or surface contamination prior to assembly.

**CAUTION:** AVOID COATING THE FIRST THREAD TO AVOID SYSTEM CONTAMINATION.

- 2 Apply a light coat of a thread lubricant (Lubon #404) to the threads of the fitting.
- 3 Screw the fitting into the port to the finger tight position.
- 4 Wrench tighten the fitting 1 to 1-1/2 turns from finger tight. Fittings that require a specific orientation to receive the incoming tube or hose assembly may be adjusted from 1 to 2 turns, beyond finger tight to achieve the desired location.

Straight thread inlet fittings and bleeder adapter fittings with o-rings are to be torqued 65-70 in-lb. Bleeder seats are to be tightened snug to preclude leakage.

**NOTE:** Cap fittings if brake is not being immediately installed on the aircraft.

- (b) Install pressure plate lining facing away from pistons by sliding over anchor bolts. Pressure plate should slide freely over anchor bolts.

- (c) Install back plates with attachment bolts and washers. Install metal or insulating shim, if applicable. Do not tighten bolts if brake is to be installed on aircraft or put into storage. Insulating (fiber) shims are used on brakes with metallic linings.
  - (d) A dry film lubricant ([Appendix B, Section B3](#) for your climate environment) should be applied to anchor bolts and torque plate bushings to assist sliding motion. Exercise care to ensure that linings do not become contaminated with fluid or lubricant. For best service life, **cylinders must slide freely in torque plate.**
  - (e) Install cylinder assembly in torque plate by sliding anchor bolts into bushings.
- (5) After installation on the aircraft, pressure test the brake assembly at 600 psi and check for leakage.

#### E. Storage

Brake assemblies which are not to be immediately installed on the aircraft must be properly stored. Acceptable storage conditions are listed below.

**CAUTION:** BRAKES STORED IN CARDBOARD BOXES, WHICH HAVE BECOME WET OR HAVE BEEN EXPOSED TO HIGH HUMIDITY, CAN BECOME CORRODED.

- (1) The length of time that an assembly can be stored is governed by its seals. Product assemblies kept in storage for an extended time without actuation can accelerate compression set in assembled seals. Compression set occurs when the seal fails to recover its form after extended time under squeeze and/or extreme temperature. It is best practice to disassemble any assembly kept in storage without actuation for one year or more and rebuild it with new seals prior to installation on aircraft. End users may utilize alternative storage intervals if product does not exhibit any appreciable effect on performance. For uninstalled seals stored under optimal conditions, current aerospace practices recognize a 60-quarter shelf life for nitrile seals; all other seals have unlimited uninstalled shelf life. The storage life may be shortened by exposure to sunlight, extreme temperatures, humidity, ozone, contamination of fluids, severe operating conditions, etc.
- (2) Normal storage environmental temperatures of 50° to 77°F (10° to 25°C) are desired. If this temperature range cannot be maintained, temperatures as high as 125°F (51.7°C) and as low as -20°F (-28.9°C) can be tolerated for shorter periods. Total time above 100°F (37.8°C) shall not exceed three months.

### 3. Wheel Assembly Off-Aircraft Maintenance

This section covers the removal, disassembly, inspection, reassembly, and installation of the main, nose, and tail wheel assemblies. When conducting wheel maintenance, observe the following general cautions:

- Careful handling of the wheel components will assure a long service life and trouble free operation.
- Strictly observe the tire deflation and inflation procedures, and the torque values specified. Wheel nut torque values are shown on the nameplate or on the outboard wheel half. Do not overtighten any bolt, nut, or fitting. Do not employ impact or power wrenches to remove or tighten any threaded parts.
- Handle the wheel bearing cones with extreme care. Many bearing failures can be traced to dropping or mishandling the cones during maintenance. Bearing cups and cones should be used as a matched set to provide maximum service life. Do not drive bearing cones onto the aircraft axle, and never overtighten the axle nut. For more information, refer to Timken Bearing Company's technical references for tapered roller bearings.

- The wheel halves should be properly maintained to protect the paint and surface finishes; exposed aluminum/magnesium is susceptible to corrosion. Nicks, scratches, and other damage caused by improper handling of the wheel halves during maintenance invite corrosion which, if unattended, could lead eventually to fatigue cracks and wheel failure.

#### A. Bearing Grease

**CAUTION:** DO NOT MIX AVIATION WHEEL BEARING GREASES WITH EACH OTHER. IF USING OTHER APPROVED GREASE, COMPLETE REMOVAL OF CONTAINED GREASE AND BEARING CLEANING IS REQUIRED. REPLACEMENT OF PREVIOUSLY LUBRICATED FELT GREASE SEALS IS ALSO REQUIRED.

**CAUTION:** THE FOLLOWING GREASE CHANGE DOES NOT APPLY TO AMPHIBIOUS APPLICATIONS NOTED IN [TABLE A4](#).

Beginning March, 2007 all active wheel assemblies listed in [Table A4](#), except those noted for amphibious application, will be shipped from the Cleveland Wheel & Brake Systems facility with the bearings packed with Mobil Aviation Grease SHC 100.

**NOTE:** If your non-amphibious wheel assembly was shipped prior to March 2007 it may contain other approved bearing grease. To change to the Mobil Aviation Grease SHC 100, you must completely remove the contained grease and clean the bearings. You must also replace any felt grease seals which were previously lubricated with other approved grease. [Refer to paragraph 3.E. \(5\) \(a\)](#) for grease packing instructions.

#### B. Removal From Aircraft

Separate removal procedures are given for the main, nose, and tail wheels.

##### (1) Removal of Main Wheel

**SAFETY WARNING** : **ENSURE AIRCRAFT IS SECURE AND STABLE BEFORE BEGINNING ANY WORK. WORKING UNDER AN IMPROPERLY STABILIZED AIRCRAFT COULD CAUSE INJURY OR DEATH.**

**NOTE:** Brake back plates must be removed for wheel removal. [Refer to paragraph 2.A](#) of this section. Hydraulic line need not be disconnected for wheel removal.

- (a) Remove wheel pants/fairings if aircraft is so equipped.
- (b) Properly raise the aircraft off the ground following the aircraft manufacturer's instructions.
- (c) Remove hubcap/wheel cover, if applicable.

**SAFETY WARNING** : **DEFLATE TIRE IMMEDIATELY AFTER JACKING AIRCRAFT AND BEFORE AXLE NUT IS LOOSENED. FAILURE TO DEFLATE TIRE BEFORE WHEEL REMOVAL COULD RESULT IN SEVERE PERSONAL INJURY.**

- (d) Remove air from tire by depressing the valve stem plunger until air can no longer be heard escaping from the tire.

**SAFETY WARNING** : **DO NOT ATTEMPT TO REMOVE VALVE CORE UNTIL TIRE HAS BEEN COMPLETELY DEFLATED. VALVE CORES WILL BE EJECTED AT HIGH VELOCITIES IF UNSCREWED BEFORE AIR PRESSURE HAS BEEN RELEASED.**

- (e) Remove valve core.
- (f) Remove cotter pin from axle and remove axle nut.
- (g) Rock wheel/tire slightly to unseat the outboard bearing.
- (h) Carefully remove and store the bearing. Label the bearing for reinstallation into position from which it was removed.
- (i) Remove wheel/tire.
- (j) Carefully remove and store inboard bearing.
- (2) Removal of Nose Wheel

**SAFETY WARNING** : **ENSURE AIRCRAFT IS SECURE AND STABLE BEFORE BEGINNING ANY WORK. WORKING UNDER AN IMPROPERLY STABILIZED AIRCRAFT COULD CAUSE INJURY OR DEATH.**

- (a) Remove wheel pants/fairings if aircraft is so equipped.
- (b) Properly raise the aircraft off the ground following the aircraft manufacturer's instructions.

**SAFETY WARNING** : **DEFLATE TIRE IMMEDIATELY AFTER JACKING AIRCRAFT AND BEFORE AXLE NUT IS LOOSENED. FAILURE TO DEFLATE TIRE BEFORE WHEEL REMOVAL COULD RESULT IN SEVERE PERSONAL INJURY.**

- (c) Remove air from tire by depressing the valve stem plunger until air can no longer be heard escaping from the tire.

**SAFETY WARNING** : **DO NOT ATTEMPT TO REMOVE VALVE CORE UNTIL TIRE HAS BEEN COMPLETELY DEFLATED. VALVE CORES WILL BE EJECTED AT HIGH VELOCITIES IF UNSCREWED BEFORE AIR PRESSURE HAS BEEN RELEASED.**

- (d) Remove valve core.
  - (e) Support wheel/tire and remove axle attachment bolts, nuts, and washers. In some cases, the nose wheel will be attached with an axle nut, similar to the main gear, which must be removed.
  - (f) Remove wheel/tire, axle spacers, and shims.
  - (g) Separate wheel/tire from axle, axle spacers, and shims. Carefully remove and store bearings. Label bearings for reinstallation into positions from which removed.
- (3) Removal of Tail Wheel

**SAFETY WARNING** : **ENSURE AIRCRAFT IS SECURE AND STABLE BEFORE BEGINNING ANY WORK. WORKING UNDER AN IMPROPERLY STABILIZED AIRCRAFT COULD CAUSE INJURY OR DEATH.**

- (a) Properly raise the aircraft off the ground following the aircraft manufacturer's instructions.

**SAFETY WARNING** : **DEFLATE TIRE IMMEDIATELY AFTER JACKING AIRCRAFT AND BEFORE AXLE NUT IS LOOSENED. FAILURE TO DEFLATE TIRE BEFORE WHEEL REMOVAL COULD RESULT IN SEVERE PERSONAL INJURY.**

- (b) Remove air from tire by depressing the valve stem plunger until air can no longer be heard escaping from the tire.

**SAFETY WARNING** : **DO NOT ATTEMPT TO REMOVE VALVE CORE UNTIL TIRE HAS BEEN COMPLETELY DEFLATED. VALVE CORES WILL BE EJECTED AT HIGH VELOCITIES IF UNSCREWED BEFORE AIR PRESSURE HAS BEEN RELEASED.**

- (c) Remove valve core.
- (d) Support wheel/tire and remove axle attachment bolts, nuts, and washers.
- (e) Remove wheel/tire, axle spacers, and shims.
- (f) Carefully remove and store bearings. Label bearings for reinstallation into positions from which removed.

### C. Wheel Disassembly

The step-by-step disassembly procedure given below is common to the main, nose, and tail wheels. Disassembly should be performed only to the level required to effect necessary repairs. When doing any wheel maintenance, the technician shall first refer to the aircraft manufacturer's maintenance manual for guidance. In the absence of detailed information from the aircraft manufacturer the technician may use the information in this publication by referring to [Figure 3 or 4](#), Typical Wheel Assemblies, or resources found at [clevelandwheelandbrake.com](http://clevelandwheelandbrake.com) for the unit being disassembled.

Cleveland products of identical part number are used on a variety of different aircraft. The combined effects of negligent service, environmental conditions and the application itself may affect the service life of the product. Therefore, a very thorough inspection of the wheel and its components is recommended whenever the tire is changed or whenever the technician determines that it is warranted.

Organizations that routinely perform their own maintenance may want to use their experiential observations to develop their own unique inspection procedures. Some organizations will perform the more thorough dye penetrant inspection after a predetermined number of tire changes with newly introduced wheel assemblies typically permitting the largest number of tire changes. The tire change to dye penetrant inspection interval will be progressively reduced as the time in service of the product increases. This type of program will eventually result in a more thorough dye penetrant detailed inspection at each tire change.

**SAFETY WARNING** : **DO NOT ATTEMPT TO DISASSEMBLE WHEEL UNTIL TIRE HAS BEEN COMPLETELY DEFLATED. SERIOUS INJURY TO PERSONNEL OR EQUIPMENT DAMAGE CAN RESULT IF THESE PRECAUTIONARY MEASURES ARE IGNORED.**

**DO NOT ATTEMPT TO REMOVE VALVE CORE UNTIL TIRE HAS BEEN COMPLETELY DEFLATED. VALVE CORES WILL BE EJECTED AT HIGH VELOCITIES IF UNSCREWED BEFORE AIR PRESSURE HAS BEEN RELEASED.**

**CAUTION:** DISASSEMBLE WHEEL ON A CLEAN FLAT SURFACE, BEING CAREFUL NOT TO NICK, SCRATCH, OR GOUGE WHEEL HALVES.

- (1) Tire Removal
  - (a) Remove valve cap and deflate tire completely.

**CAUTION:** DO NOT PRY BETWEEN WHEEL FLANGE AND TIRE BEADS, AS THIS COULD CAUSE DAMAGE TO WHEEL AND TIRE.

- (b) Separate tire beads from wheel halves, using a bead breaker or by applying pressure in even increments around the entire sidewall of the tire as close to the tire beads as possible. Suggestion: Fabricate two each rings from a substantially thick piece of plywood. The inside diameter should be slightly larger than the wheel rim outside diameter. Sandwich the wheel/tire between the two rings and apply pressure to the top ring. The tube well area of the wheel is tapered and once the bead is broken the tire should slide progressively easier. Ref. Figure 306.

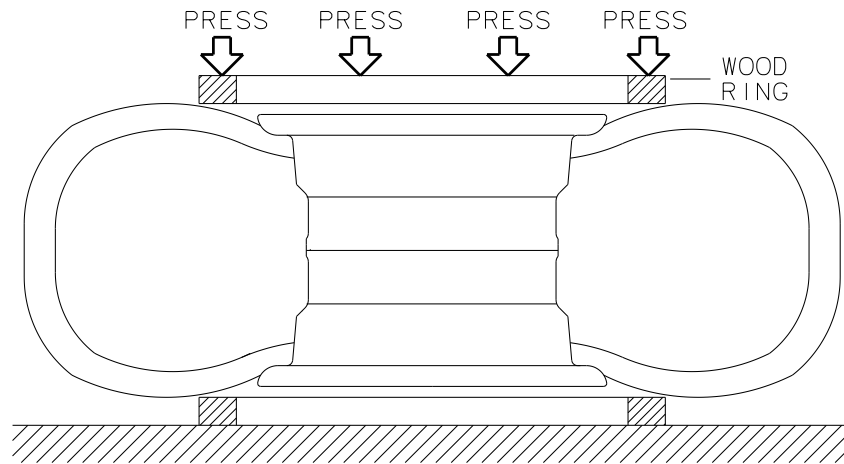

Figure 306 - Tire Removal

- (c) Remove nuts (5), washers (6), and bolts (7) holding wheel halves together. If brake disc bolts are separate from wheel tie bolts, remove them and separate brake disc (11) from wheel.
- (d) Separate inner wheel half (10), outer wheel half (8), and brake disc (11), and remove tire. Mark wheel halves to note relationship to each other for reassembly.
- (2) Bearing Cone Removal

Remove hubcap/wheel cover, grease seals, and bearing cones. Use caution in handling bearing cones to prevent damage or contamination.

**CAUTION:** USE CARE IN REMOVING OUTBOARD WHEEL HALF TO PREVENT DAMAGE TO INFLATION VALVE STEM.

## (3) Inflation Valve Removal

Remove o-ring (9) and inflation valve if wheel is designed for use with a tubeless tire. Mark o-ring with respect to wheel half for reassembly. Retaining o-ring position will aid in minimizing leakage at reassembly. It is recommended that the o-ring be replaced at reassembly.

## (4) Bearing Cup Removal

The bearing cup is a shrink fit into the wheel half and should not be removed, unless replacement is necessary due to scratches, nicks, pitting, corrosion, or evidence of overheating.

**WARNING: USE PROTECTIVE GLOVES WHEN HANDLING HEATED PARTS.**

- (a) If replacement is necessary, place wheel half in an oven not exceeding 212°F (100°C) for 15 minutes.

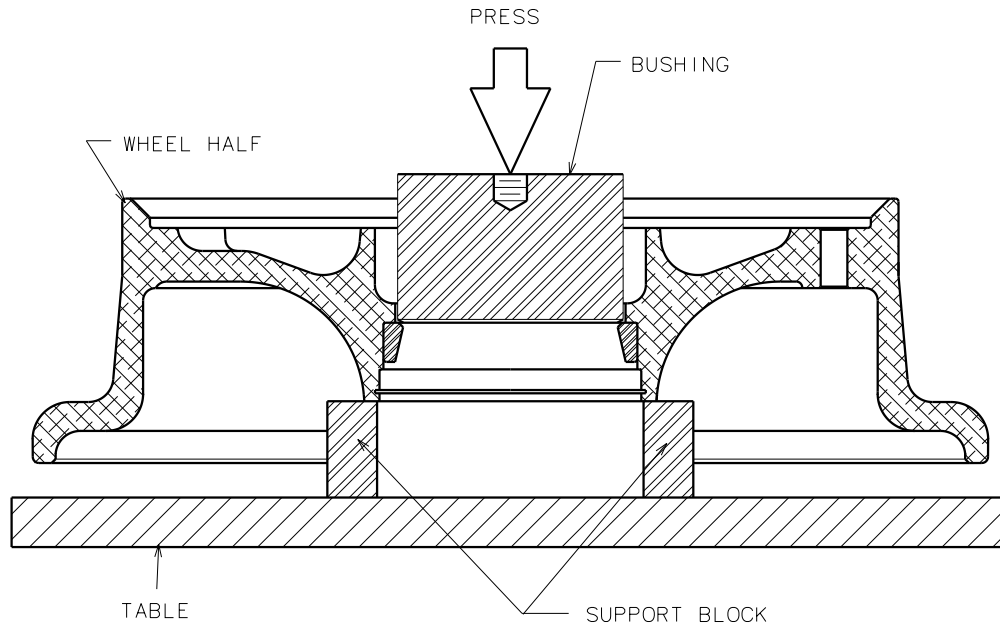

Figure 307 - Bearing Cup Removal

- (b) Remove wheel half from heat source and immediately remove bearing cup. If bearing cup does not fall out, tap it evenly with a fiber drift pin or use a suitable arbor press.

## D. Inspection

- (1) Visually inspect wheel halves for cracks, nicks, corrosion, or other damage. Any cracks in the wheel half are cause for replacement of wheel half. The tire bead seat area of a wheel (Fig 308) is typically an area of stress concentration and possibly subjected to trauma from tire beads and tools used to remove tires. These combined effects warrant that this area receive special attention when inspecting for defects. All defect indications must be thoroughly investigated to determine part airworthiness. Dye penetrant inspection and visual examination is an effective method to evaluate a defect indication. To facilitate the inspection process it is recommended that the paint be stripped in the area being evaluated.

The use of alternate inspection methods such as eddy current can also be very effective when performed by an experienced NDT Technician. Cleveland has not developed the acceptance standards or tooling for eddy current inspection techniques. Maintenance facilities that want to use this method will have to locally develop tooling and acceptance standards that adequately identify defects.

Replace any cracked or excessively corroded parts. Small nicks, scratches, or pits may be blended out and polished with fine sandpaper. Treat and repaint per [paragraph 4. Brake and Wheel Refinishing](#).

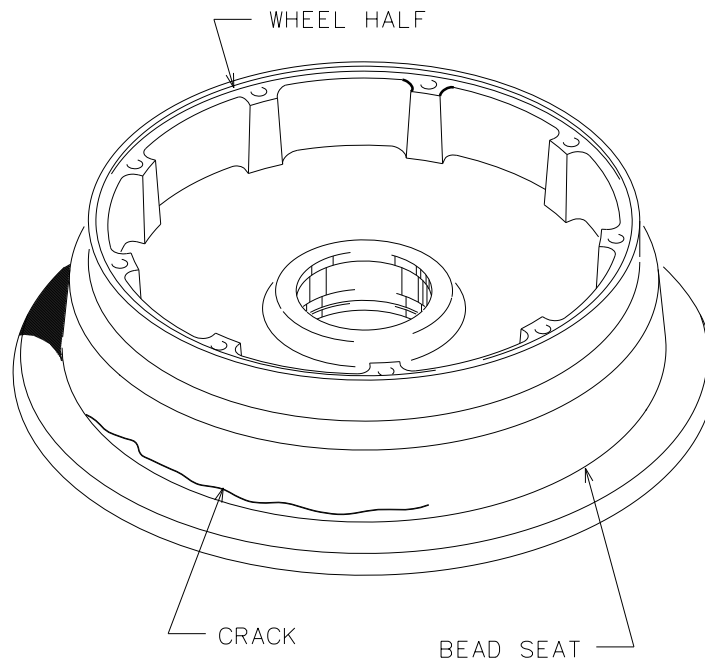

Figure 308 - Bead Seat Inspection

- (2) Inspect wheel bearing grease for contamination and solidification at each periodic inspection. Repack bearings with fresh grease – [Refer to paragraph 3.A. Bearing Grease](#).

**NOTE:** Repack wheel bearings per aircraft OEM requirements, at tire change or annual inspection (12 months), whichever comes first. If aircraft wheel uses felt seals, do not exceed 500 wheel miles (804.5 km) or annual inspection (12 months), whichever comes first between repacking intervals.

- (3) Inspect wheel half bearing cup bore for burrs, primer residue, or foreign matter. Make sure surface is clean.
- (4) Inspect snap rings and grease seals for distortion or wear. Replace grease seal felts if they are hard or contaminated. Lightly coat all surfaces of the new felt with the wheel bearing grease ([refer to paragraph 3.A. Bearing Grease](#)). Molded rubber grease seals should be replaced if cracked, dried out or distorted.
- (5) Wheel tie bolts by nature of their application are subjected to fatigue type loads. It is best to replace these fasteners at overhaul. If bolts are to be reused they must be inspected for cracks, bending, thread damage, or excessive corrosion. Bolts with evidence of any of these should be replaced with bolts of corresponding part numbers, as specified in the Cleveland Parts List found at [clevelandwheelandbrake.com](http://clevelandwheelandbrake.com). Magnetic particle inspection is the recommended procedure for bolt inspection. Alternate nondestructive inspection techniques, such as ultrasonic inspection, can demonstrate determination of non-airworthy ferromagnetic products consistent with the fluorescent magnetic particle methods. Cleveland typically uses AN, MS, and NAS bolts which, as part of the procurement specification, employ the fluorescent magnetic particle inspection as one of the recognized standards in determining acceptance of product. Therefore, the acceptance standards and methodologies for the ultrasonic inspection techniques have not been specifically developed at Cleveland. Use of the ultrasonic method or any other inspection techniques is the responsibility of the agency determining airworthiness of the product.

**NOTE:** Inspect self-locking nuts for damage. If nut can be turned onto bolt by hand, past the nut's self-locking section, it should be replaced with nuts of corresponding part numbers.

- (6) Replace o-rings with o-rings of corresponding part numbers. If necessary, o-rings may be reused. Inspect o-rings for cuts, nicks, distortion, or excessive wear. Check to be sure o-ring has not become brittle or hard.

**NOTE:** Brake disc cracks are not allowed unless covered by a PRM (Product Reference Memo) or SB (Service Bulletin) issued specifically for a brake disc.

- (7) Inspect brake disc for cracks, excessive wear, or scoring, mounting hole elongation, corrosion, and warpage. Remove corrosion and blend out small nicks using fine (400 grit) sandpaper. Replace brake disc if worn below wear limits detailed in [Appendix A](#). Coning of disc in excess of 0.015 inch (0.381 mm) is cause for replacement. [Ref. Figure 309](#).

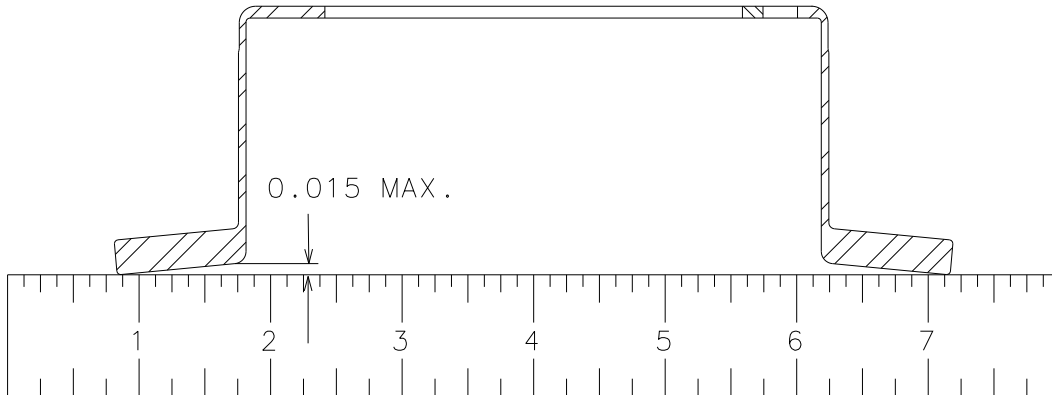

Figure 309 - Disc Coning Limits

- (8) Welded brake discs will have a slight gap on the side opposite the weld at the cup interface. This is normal. Ref. Figure 310.
- (9) Heat created during braking promotes the development of corrosion and pitting at the flange to cup area. Annually, or on condition, sandblast these areas or use a wire wheel to remove corrosion and pitting. Treat affected areas with zinc chromate primer and a coat of heat resistant spray paint. Heat resistant paints may be locally procured from auto parts supply.

**NOTE:** Corrosion, if left unattended will result in decreased service life of the part.

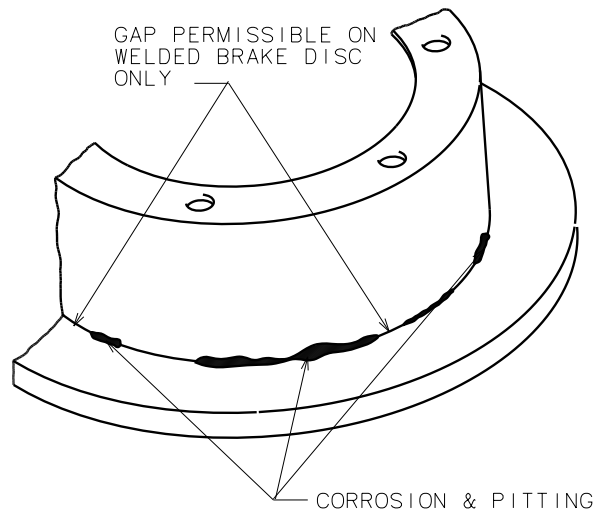

Figure 310 - Disc Inspection

### E. Wheel Reassembly

Reassembly of the wheel assembly is essentially the reverse of the disassembly procedures detailed in paragraph 3B of this section. Assemble the wheel on a clean, flat surface, being careful not to nick, scratch, or damage protective finish or wheel halves.

**NOTE:** If bearing cup was removed, use the following procedure for installation of a new bearing cup.

#### (1) Bearing Cup Installation

**WARNING: USE PROTECTIVE GLOVES WHEN WORKING WITH DRY ICE OR HANDLING HEATED PARTS.**

- (a) Place wheel half in an oven not exceeding 212°F (100°C) for 15 minutes. Chill new bearing cup in an atmosphere of -25°F to -65°F for no less than 4 hours. Chilling may also be accomplished by placing the bearing cup in dry ice for a minimum of 15 minutes.
- (b) To install a new bearing cup, apply one coat of zinc chromate to cup bore.
- (c) Remove wheel half from heat source and remove bearing cup from cold source. Dry cup thoroughly.
- (d) Install the chilled bearing cup into bearing bore of heated wheel half. Tap gently into place with a fiber drift making sure cup is evenly seated against shoulder of wheel half. [Ref. Figure 311](#). Avoid cocking bearing cup during installation. If bearing cup will not seat properly in wheel half, repeat above procedure or replace wheel half assembly.

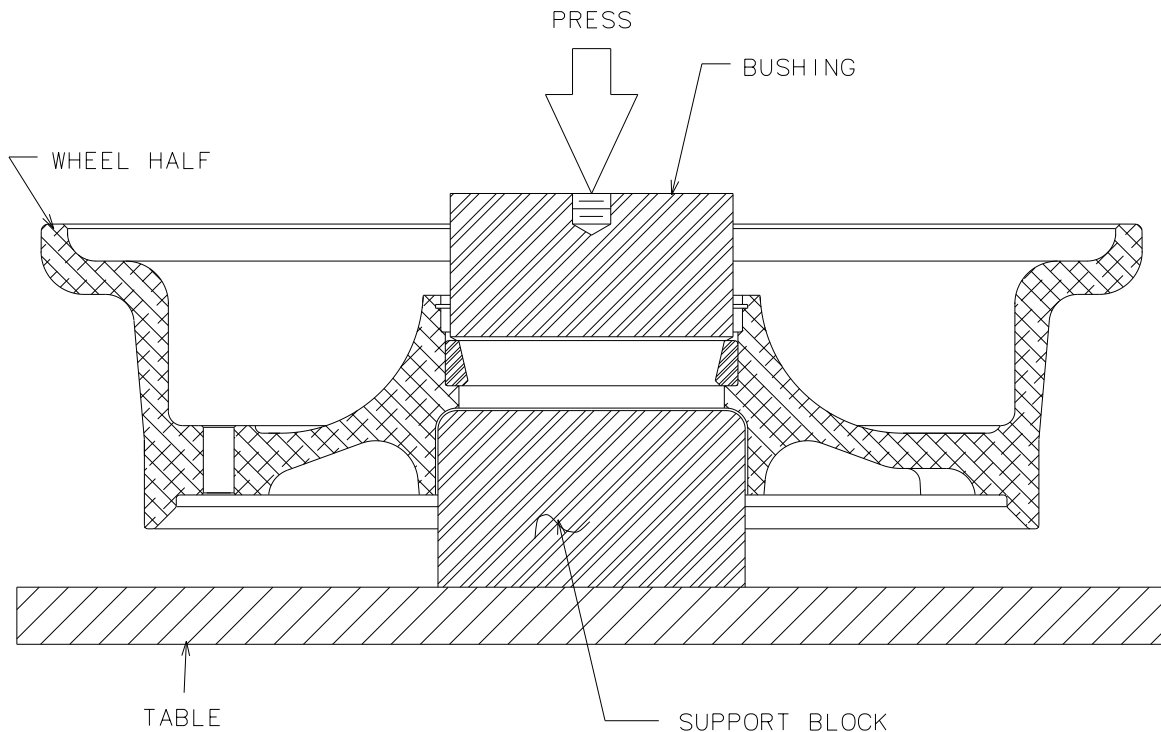

Figure 311 - Bearing Cup Installation

## (2) Tire Mounting

**NOTE:** Prior to mounting, make sure tire is clean. Inspect bead area and wipe it clean with denatured alcohol, followed by soap and water, then thoroughly dry the bead area prior to mounting. A dry lube (talc only) can be used between the mating surfaces of wheel halves to aid in the assembly and disassembly process.

## (a) Tubeless Tires

- 1 Check for the word TUBELESS on sidewall. Make sure tire is clean inside. Inspect bead area and wipe it clean with denatured alcohol, followed by soap and water. Dry thoroughly and use only dry talc to aid installation.
- 2 Wipe the bead seat and o-ring seal area of wheel halves with an alcohol dampened cloth. Lubricate o-ring seal with a light coat of grease MIL-G-4343 (Dow Corning 55 O-Ring compound) or equivalent and place it carefully in its groove without stretching or twisting.

- 3 Place the tire on the inboard wheel half being careful not to disturb the o-ring. Position the red (light spot) balancing dot on the tire adjacent to the wheel valve.
- 4 Place outboard wheel half inside the tire. Align marks made at disassembly with those on inboard half.

(b) Tube-Type Tires

**NOTE:** Tire slippage may occur with new, unused tires, tubes, and wheel. Wiping the tire and tube with denatured alcohol, followed by soap and water.

- 1 Make sure the inside of the tire is clean and dry. Inspect bead area and wipe it clean with denatured alcohol, followed by soap and water, then dry thoroughly.
- 2 Inflate the inner tube just enough to round it out.
- 3 Install the inner tube with the yellow strip (or equivalent heavy spot marking) adjacent to the red (light spot) balance dot on the tire. If the tube has no balance mark, place valve adjacent to tie balance dot.
- 4 Install the tire and inner tube on the outer wheel half, inserting the valve stem through the valve hole in the wheel. Place the inner wheel half inside the tire. Align the marks made at disassembly with those on the outer wheel half.

(3) Disc Installation

Disc installation applies only to the main wheel. Brake discs may be attached to the wheel in either of the two ways detailed below.

**NOTE:** Replace discs only with factory authorized replacement discs to obtain full warranty protection.

(a) Brake Disc Attached with Wheel Tie Bolts

**NOTE:** Fasteners should be torqued to the value stated on the casting/nameplate. Do not add the torque required to turn the nut (free running torque).

**WARNING:** FAILURE TO PROPERLY TORQUE THE WHEEL ASSEMBLY TIE BOLTS MAY RESULT IN PREMATURE FAILURE OF THE MATING COMPONENTS OR HARDWARE.

- 1 Install disc in inner wheel half and align bolt holes with wheel half.

**NOTE:** All Torque values listed on Cleveland Products are considered to be “DRY TORQUE” values unless a thread lubricant is specified conforming to either SAE AMS2518 (ref MIL-T-5544) or MIL-PRF-83483 (Molydisulphide) and applied to all friction surfaces as shown in Figure 312. Only use the thread lubricant specified for your wheel assembly.

**CAUTION:** TORQUING A FASTENER TO A DRY TORQUE VALUE WITH THREAD LUBRICANT APPLIED CAN RESULT IN AN OVER TORQUED CONDITION FOR THE FASTENERS OR ASSEMBLY.

**NOTE:** Product received from Cleveland with thread lubricant applied is correct for that particular product and will be so designated on service publications. When in doubt - call Cleveland.

- 2 Install bolts through brake disc and wheel halves. Both plain and countersunk washers may be used. Some designs use bolts that have a radius between the head and shank, which requires the countersunk washers. Inspect bolts and washers prior to assembly. (Ref. Figure 312). Properly oriented washers with countersunk surfaces to sit flush against the bolt head. Install washers and nuts on bolts (bolt heads are to be on brake disc side of wheel). Apply torque to the nut while holding the bolt head. Snug all the nuts in a crisscross pattern to seat the flange. Then torque the nuts to final value specified on wheel casting or nameplate, using a crisscross pattern until all nuts are properly torqued. Verify all bolts have been torqued properly by going around the bolt pattern with a torque wrench. Do not use power tools for the installation of nuts and bolts.

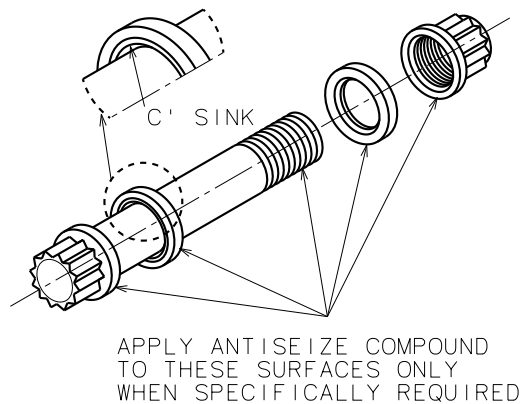

Figure 312 - Wheel Tie Bolts

(b) Brake Disc Not Attached With Wheel Tie Bolts

- 1 Install brake disc in inner wheel half and align bolt holes with wheel half inserts.
- 2 Install bolts through brake disc, thread into each insert, and torque to 150 in-lbs (1034 kPa).
- 3 Install wheel bolts, washers, and nuts.

## (4) Inflation Valve Installation

Two configurations of inflation valve stems, grommet and the o-ring types, are used for tubeless tire applications. Both types should have either the rubber bushing (grommet) or the o-ring coated with Dow Corning 55 O-Ring Lubricant prior to installation. Torque to all the appropriate values as listed in the [Appendix A4](#) and [A5](#).

## (5) Bearing Installation

**CAUTION:** DO NOT MIX AVIATION WHEEL BEARING GREASES WITH EACH OTHER. REFER TO PARAGRAPH 3.A. BEARING GREASE.

**CAUTION:** HANDLE BEARING CONES WITH EXTREME CARE TO PREVENT CONTAMINATION OR DAMAGE.

## (a) Pack the bearing cones as follows.

The correct application of grease to the tapered roller bearing will reduce friction, dissipate heat and maintain a rust and corrosion proof coating on the operating surfaces of the roller bearings.

**NOTE:** Pack the bearing cones just before installation to prevent contamination.

**NOTE:** Bearing cones can be packed by hand or by using a mechanical bearing greaser. The mechanical bearing greaser will do a more thorough job of packing the grease.

- 1 Clean the bearing cones. [Refer to paragraph 4.A. Degreasing.](#)
- 2 Push and force the grease up and out between the rollers, cone and cage.
- 3 The bearing is properly greased when no voids or daylight can be observed between the rollers and inner and outer races.
- 4 Disperse excess grease around each end and the tapered sides of each cone.

**NOTE:** Shaded area shows the recommended quantity of grease.

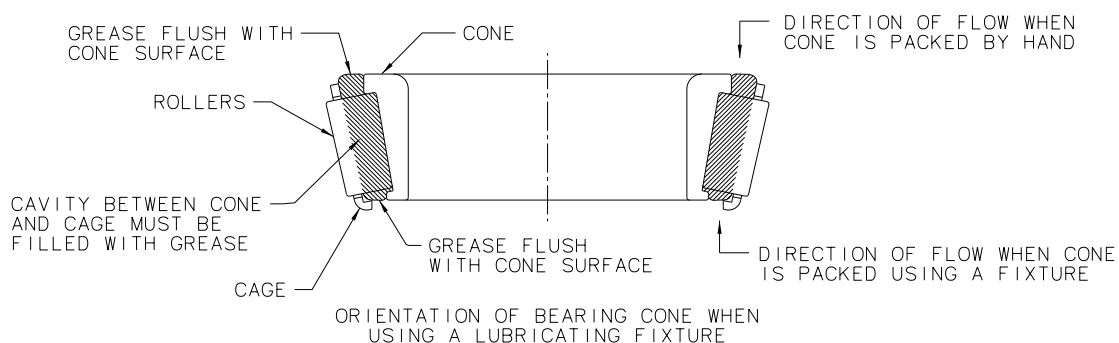

Figure 313 - Packing Bearing Cones

- (b) Liberally swab the bearing cup, bearing bore hub and grease seal/snap ring areas with bearing grease.
  - (c) If felt seals are used, lightly coat all surfaces of the felt with the wheel bearing grease ([refer to paragraph 3.A. Bearing Grease](#)). If rubber lip seals are used, lightly coat all contact surfaces of the seal with bearing grease. (Including inside and outside diameter).
  - (d) Install the bearing cones, grease seals (felts and rings or rubber lip seals) and snap rings.
    - 1 Excess grease will squeeze out. Remove the excess grease with an inward rotating movement against the bearing cone ID. Disperse any small amounts of grease on the exterior surface of the grease seal and snap ring and remove any grease from the hub outside surface.
  - (e) Install hubcap/wheel cover if part of wheel assembly. Use care that bearing grease does not become contaminated.
- (6) Tire Inflation

**SAFETY WARNING**  **PLACE THE WHEEL/TIRE IN AN INFLATION CAGE FOR INITIAL INFLATION, TO PREVENT INJURY TO PERSONNEL FROM POSSIBLE EXPLOSION.**

- (a) Inflate tire to tire manufacturer's specifications to seat beads on wheel. Deflate tire to 10 psi (68.9 kPa) for storage.
- (b) Place protective cover over bearing hubs to prevent contamination of grease or bearing damage during storage of wheel.

#### F. Storage

Wheel storage procedures differ depending on whether the wheels are stored with or without tires installed.

**CAUTION:** WHEELS STORED IN CARDBOARD BOXES, WHICH HAVE BECOME WET OR HAVE BEEN EXPOSED TO HIGH HUMIDITY, CAN BECOME CORRODED.

##### (1) Wheels Stored With Tires Installed

- (a) The length of time that a wheel assembly can be stored is governed by the storage life of its rubber components. Basically, rubber components are considered to have a usable life of up to ten years from the date of cure. The usable life may be shortened by exposure to sunlight, extreme temperatures, and low humidity; contamination by fluids; severe operating conditions, etc.
- (b) The wheel assembly should be stored in a clean, dry storeroom. The desirable storeroom temperature range is from 50° to 77°F (10° to 25°C). If this temperature range cannot be maintained, temperatures as high as 125F (51.7°C) and as low as -20°F (-28.9°C) can be tolerated for shorter periods. Total time above 100°F (37.8C) shall not exceed three months. The recommended storage pressure for tires is 10 psi (68.9 kPa).

- (2) Wheels Stored Without Tires Installed
  - (a) Short-term storage of tubeless wheel assemblies may be stored with the wheel o-ring packing installed between the two halves.
  - (b) Storage of components containing rubber longer than two years should be assembled without the o-ring packing. O-rings to be placed in an ultraviolet protective package.
  - (c) Wheels stored without rubber components installed have an indefinite storage life.

#### 4. Brake and Wheel Refinishing

Complete procedure necessary to remove existing paint from brake and wheel components and then to repaint them is described in the following paragraphs.

##### A. Degreasing

**SAFETY WARNING** : **CLEANING SOLVENTS CAN BE TOXIC AND VOLATILE. USE ONLY IN WELL VENTILATED AREAS. AVOID PHYSICAL CONTACT WITH SOLVENT AND DO NOT INHALE VAPORS. KEEP SOLVENT CONTAINERS COVERED WHEN NOT IN USE.**

- (1) Clean all metal parts by immersing in a clean degreasing solution. An alkaline based solution is recommended for aluminum and magnesium parts.
- (2) Hardened dirt or grease may be removed with a soft bristle brush, or by soaking in cleaning solution.
- (3) Clean bearing cones carefully in a separate container of mineral spirits.

**CAUTION:** DO NOT SPIN BEARING CONES WITH COMPRESSED AIR.

- (4) After cleaning, thoroughly dry all metal parts with filtered dry compressed air.
- (5) It is recommended that all o-rings, back-up rings and wipers be replaced at each overhaul. However, if necessary, o-rings may be reused but should be put back into position from which removed.
- (6) Wipe down o-rings, back-up rings, wipers, or other rubber parts with a clean dry cloth. Lubricate with a suitable o-ring lubricant prior to installation.

**B. Paint Removal**

Disassemble brake and wheel components to the level required for repainting, then proceed as follows:

- (1) Degrease part per [paragraph 4.A.](#)
- (2) Cleveland recommends the use of plastic media stripping techniques to be performed per equipment manufacturer's recommended instructions.

**NOTE:** Chemical stripping agents are commercially available for removing topcoat and primer, and may be used if plastic media stripping equipment is not available. Follow manufacturer's recommendations for use and disposal of stripping solutions. If chemical stripping is used, the Bearing Cup must be removed from the wheel half assembly prior to proceeding.

**SAFETY WARNING** : **CHEMICAL STRIPPING AGENT SOLVENTS CAN BE TOXIC AND VOLATILE. USE ONLY IN WELL VENTILATED AREAS. AVOID PHYSICAL CONTACT WITH SOLVENT AND DO NOT INHALE VAPORS. KEEP STRIPPING AGENT SOLVENT CONTAINERS COVERED WHEN NOT IN USE.**

**WARNING:** **DO NOT SANDBLAST. SANDBLASTING IS TOO ABRASIVE AND WILL DAMAGE SMOOTH PISTON BORE OR O-RING SEAL AREAS.**

- (3) Rinse part thoroughly with water heated to 160° to 180°F (71° to 82°C). If used, flush chemical stripping agent solvent from all cavities and threaded holes where entrapment might occur.
- (4) Thoroughly dry part with filtered, dry compressed air.
- (5) Refer to inspection procedures in [paragraph 2.C.](#) for specific parts to locate possible defects.

**NOTE:** Refinishing should be completed as soon as possible; unprotected parts will begin to corrode.

### C. Surface Pretreatment

All cast products are to be surface pretreated after any nicks, dings, corrosion, or other discontinuities have been mechanically removed. It is necessary to know the cast alloy material such that the proper treatment can be performed. Both aluminum and magnesium alloy casting are used in products at Cleveland. Refer to [A3. Brake Assembly Back Plate Tie Bolt Torque](#) and [A4. Wheel Assembly Torque Values](#) table for material identification.

- (1) Aluminum parts should have a protective barrier between the topcoat and base material. It is recommended they be treated with conversion coating per MIL-C-5541, Class 1A (Alodine).

**NOTE:** Alodine is ineffective on magnesium.

- (a) Apply solution liberally and evenly. Allow it to set from 1 to 5 minutes. The solution must completely wet the surface and overlap onto the adjoining anodize.
- (b) Remove excess coating by flushing with clean water.

**SAFETY WARNING** : **RUBBER GLOVES AND EYE PROTECTION SHOULD BE WORN WHEN MIXING AND APPLYING THIS SOLUTION. CARE SHOULD BE EXERCISED TO PREVENT SKIN CONTACT. WASH EXPOSED AREAS IMMEDIATELY WITH COLD WATER AND SOAP.**

- (2) Magnesium parts may be treated with surface pretreatment per MIL-M-3171, Type VI, Chromic Acid or Oxsilan®.

**NOTE:** MIL-M-3171 Type VI is ineffective on aluminum and Oxsilan® is currently not being used on aluminum specified applications.

MIL-M-3171 Type VI (for use on parts with a dull bronze to bright gold surface treatment appearance).

- (a) Apply mixed solution liberally at room temperature and allow to dry. Parts may be dipped for 1/2 to 2 minutes in solution at room temperature.
- (b) Remove excess coating by flushing with clean, cold water.
- (c) Dry in oven or hot air. Never rinse in hot water.
- (d) Alternate option would be to re-coat with Oxsilan® (see instructions below).

Oxsilan® (for use on parts with a clear to iridescent surface treatment appearance).

- (a) Scrub surface with an abrasive material such as Scotch-Brite™ pad.
- (b) Rinse surface with water.
- (c) Wipe excess water with clean cloth.
- (d) Spray with a liberal amount of Oxsilan® so that the entire scrubbed area is saturated.
- (e) Let stand for 5 minutes (to expedite the drying process, a mild airflow source can be used).

**SAFETY WARNING** : **EXPOSURE TO CADMIUM DUST IN UNVENTILATED GRINDING ACTIVITIES AND WORKING WITH CADMIUM AND ITS COMPOUNDS CAN BE A POTENTIAL HEALTH HAZARD.**

- (3) Stripping and re-cadmium plating steel parts is generally cost prohibitive in small lot sizes. Therefore, steel parts that have been cadmium plated may be protected with an application of zinc rich cold galvanizing compound or zinc chromate. Finish with an application of a good quality topcoat.

#### D. Repainting

Refer to Figures 314, 315, 316 to identify surfaces of brake and wheel components that require paint. Proceed as follows:

- (1) Parts to be repainted should be cleaned and stripped per instructions in degreasing and paint removal paragraphs 4.A. and 4.B.
- (2) Pretreat surface using appropriate materials per paragraph 4.C.
- (3) Coat parts with one thin coat of zinc chromate primer or equivalent. Allow to dry thoroughly.

**NOTE:** Prior to prime and paint, mask any areas which had not previously been coated. This includes Cylinder piston bores, all internal threads and ports, Wheel Half seal and bearing bores (to be primed only), and Bearing Cups.

- (4) Paint parts with one coat of locally obtained, finish enamel, polyurethane, epoxy or lacquer to match original color. Allow to dry thoroughly before reassembly.

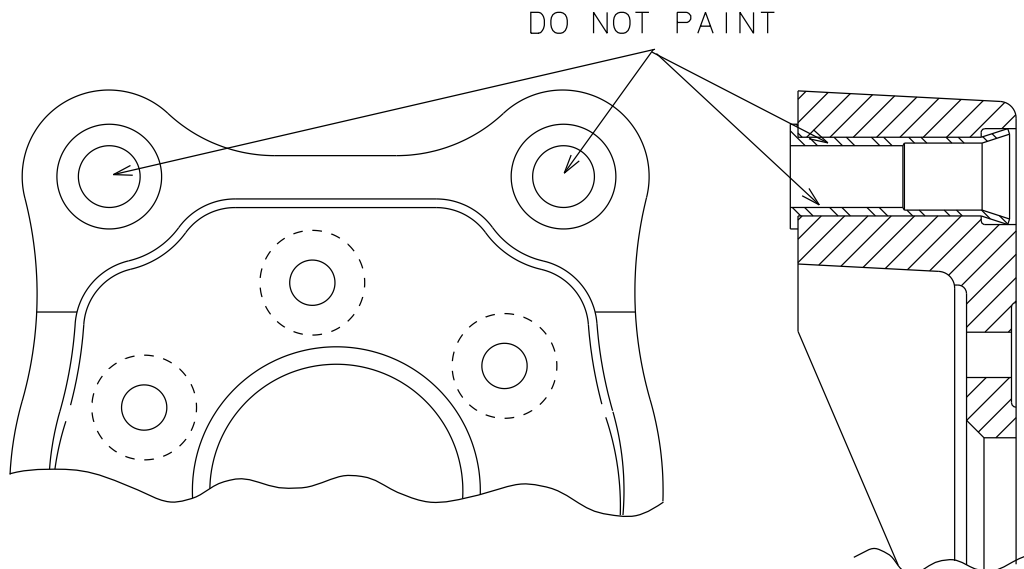

Figure 314 - Typical Torque Plate (Cast), Painted Surfaces

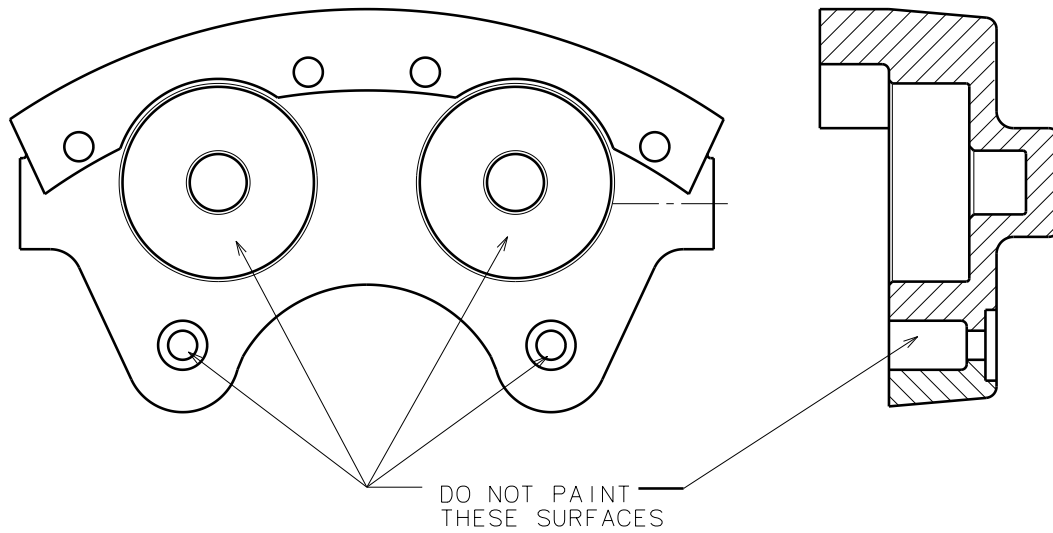

Figure 315 - Typical Brake Cylinder, Painted Surfaces

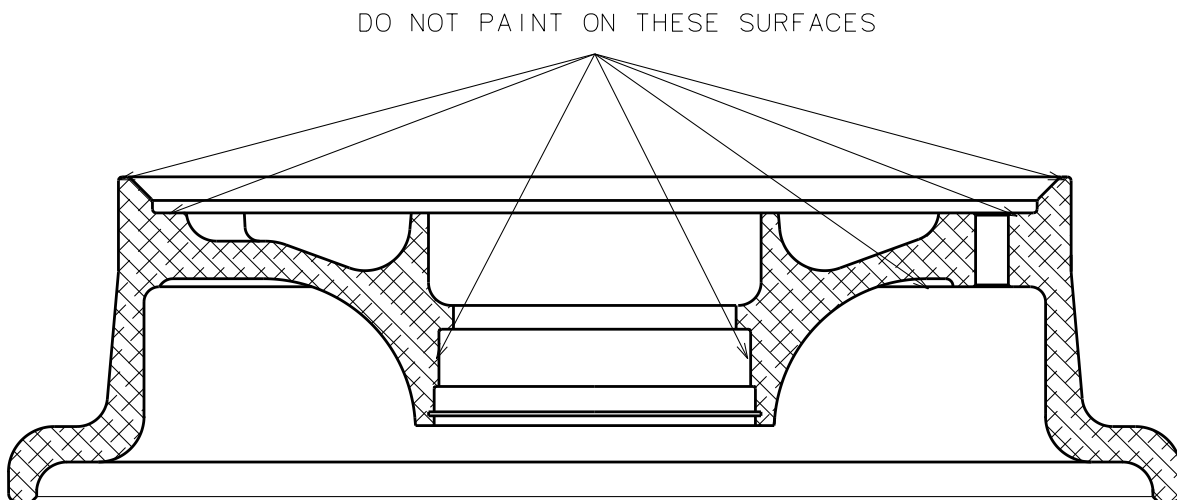

Figure 316 - Typical Wheel Half, Painted Surfaces

## 5. Installation of Brake and Wheel Assemblies Onto Aircraft

### A. Brake Installation

- (1) If torque plate was removed, install it in the same rotational orientation as when removed. Install torque plate on axle flange with attachment bolts, nuts, and washers. Torque nuts to level specified in aircraft manual.
- (2) If wheel had been removed, install wheel per instructions in [paragraph 5.B.](#) of this section prior to installing brake cylinder assembly.
- (3) Remove back plate attachment bolts, washers, and back plates.
- (4) A dry film lubricant ([Appendix B, Section B3](#) for your climate environment) should be applied to anchor bolts and torque plate bushings to provide ease of installation and operation. Reapply dry film lubricant periodically as required to maintain friction free operation.
- (5) Install cylinder in torque plate by sliding (do not force) anchor bolts into torque plate bushings.  
**NOTE:** A liquid type lubricant should not be used as it will attract dirt and moisture, thereby enhancing the possibility of corrosion, binding, and wear.
- (6) Install back plates, shims, or insulators, if applicable, and back plate attachment bolts and washers. Torque attachment bolts to level specified in Bolt Torque Values listed in [Appendix A.](#)
- (7) Uncap and attach hydraulic line to cylinder inlet fitting.
- (8) Bleed the system in accordance with the aircraft service manual. Using the CWBS bleeder assembly, P/N 087-00500, will simplify this operation. Use the bleeder as follows:
  - (a) Remove the rubber bleeder fitting cap.
  - (b) Loosen the AN815 4D fitting, place the bleeder screw into the slot on the 087-00500 bleeder assembly.
  - (c) Finger tighten to center the bleeder screw, then wrench tighten with light pressure (do not over tighten).
  - (d) Attach the bleeder hose.
  - (e) Open the bleeder screw 1 to 2 turns.
  - (f) The system is now ready to be bled.
  - (g) After the system is properly bled, tighten the bleeder screw, loosen and remove the bleeder assembly, then replace the rubber bleeder fitting cap.
- (9) After accomplishing system bleeding, depress and release toe pedal several times, checking for brake drag by rotating the wheel by hand. A slight amount of drag is normal; however, a tightly bound wheel should be investigated and corrected prior to aircraft release to service.

(10) Condition linings in accordance with PRM13A for organic materials and PRM14A for Metallic materials. [Refer to Lining Conditioning Procedures in Section 200.](#)

## B. Wheel Installation

Separate installation procedures for the main, nose, and tail wheels are given in the following paragraphs.

### (1) Main Wheel

**SAFETY WARNING**  : **ENSURE AIRCRAFT IS SECURE AND STABLE BEFORE BEGINNING ANY WORK. WORKING UNDER AN IMPROPERLY STABILIZED AIRCRAFT COULD CAUSE INJURY OR DEATH.**

- (a) Properly raise the aircraft off the ground following the manufacturer's instructions.
- (b) If Brake is installed, ensure back plate attachment bolts, washers, and back plates are removed.

**CAUTION:** INFLATION OF TIRE CAN BE EXTREMELY DANGEROUS AND IT IS RECOMMENDED THAT INFLATION BE PERFORMED IN AN INFLATION CAGE, PRIOR TO INSTALLATION ON AIRCRAFT.

- (c) Check tire inflation pressure. Carefully inflate if not to specified level.
- (d) Check to be sure that the wheel bearings are installed and lubricated, and that the felt grease seal surfaces were lightly coated with the wheel bearing grease ([refer to paragraph 3.A. Bearing Grease](#)).
- (e) Carefully slide wheel/tire onto axle making sure inboard bearing is seated.
- (f) Install axle nut.

**NOTE:** Axle nut torquing procedures vary considerably. The following procedure is based on the best available service information.

- (g) Torque axle nut using value specified in aircraft manual or the following:
  - 1 Rotate the wheel/tire while tightening axle nut to 150 to 200 inch-pounds (16.9 to 22.6 N•m) to seat the bearing.
  - 2 Back off axle nut to zero torque.
  - 3 Tighten axle nut to 30-40 inch-pounds (3.4 to 4.5 N•m) while rotating wheel/tire.
  - 4 Rotate axle nut (clockwise or counterclockwise) to nearest slot and cotter pin hole, and insert cotter pin. Bend ends of cotter pin around axle nut. Note: Wheel must rotate freely without perceptible play.

- (h) Install back plates, shims, or insulators, if applicable, and back plate attachment bolts and washers. Torque attachment bolts to level specified in [Bolt Torque Values](#) listed in [Appendix A](#).
  - (i) Check to ensure lining steel carrier plate is tight against the pressure plates / back plates. [Ref Figure 201](#).
  - (j) Carefully lower aircraft to ground following manufacturer's instructions.
  - (k) Actuate brake pedal prior to towing or taxiing. Check lining for proper alignment and engagement onto pins. Lining steel carrier plate should be seated on back plate or pressure plate. [Ref. Figure 201](#).
- NOTE:** Actuating the brake pedal will ensure pistons are extended prior to towing or taxiing. This will minimize running clearance for proper placement of linings.
- (l) Replace wheel pants, if applicable.
  - (m) Recheck tire inflation pressure.
- (2) Nose Wheel

**SAFETY WARNING**  **ENSURE AIRCRAFT IS SECURE AND STABLE BEFORE BEGINNING ANY WORK. WORKING UNDER AN IMPROPERLY STABILIZED AIRCRAFT COULD CAUSE INJURY OR DEATH.**

- (a) Properly raise the aircraft off the ground following the manufacturer's instructions.
- (b) Check to be sure that the wheel bearings are installed and lubricated, and that the felt grease seal surfaces were lightly coated with the wheel bearing grease ([refer to paragraph 3.A. Bearing Grease](#)).
- (c) Check tire inflation pressure. Refer to aircraft service manual for proper inflation value.
- (d) Install axle, axle spacers, and shims on nose wheel for fork type assemblies.
- (e) Install nose wheel/tire in fork and install axle attachment bolts, washers, and nuts. Torque nuts and bolts to level specified in aircraft manual.
- (f) On axle-type nose struts, wheel installation would be as defined in [paragraph 5.B.\(1\)](#).
- (g) Carefully lower aircraft to ground following manufacturer's instructions.
- (h) Replace wheel fairings, if applicable.
- (i) Recheck tire inflation pressure.

## (3) Tail Wheel

**SAFETY WARNING** : **ENSURE AIRCRAFT IS SECURE AND STABLE BEFORE BEGINNING ANY WORK. WORKING UNDER AN IMPROPERLY STABILIZED AIRCRAFT COULD CAUSE INJURY OR DEATH.**

- (a) Properly raise the aircraft off the ground following the manufacturer's instructions.
- (b) Check to be sure that the wheel bearings are installed and lubricated, and that the felt grease seal surfaces were lightly coated with the wheel bearing grease ([refer to paragraph 3.A. Bearing Grease](#)).
- (c) Check tire inflation pressure. Refer to aircraft service manual for proper inflation value.
- (d) Install axle, axle spacers, and shims on tail wheel.
- (e) Install tail wheel/tire in fork and install axle attachment bolts, washers, and nuts. Torque nuts and bolts to level specified in aircraft manual.
- (f) Carefully lower aircraft to ground following manufacturer's instructions.
- (g) Recheck tire inflation pressure.



**Wear Limits**

**A1. Brake Lining Wear Limits**

The minimum replacement thickness on metallic and organic linings is 0.100 inch (2.54 mm). Refer to Figure A1.

**Note:** On some designs the metallic lining is bonded directly to the pressure plate and back plate. In these cases, the part should be replaced when the lining material is worn to 0.030 inch (0.76 mm) thick.

For equipment used on Piper Aztec (using either 164-00206 or 164-03206 disc), see PRM19 or follow the procedure below:

- First, measure linings as shown in Figure A1. Linings worn below .100 inch are cause for replacement.
- If linings are still usable or are replaced, measure the cumulative thickness of two linings, disc, and pressure plate as shown in Figure A1-1. If the stack measures less than 1.00 (1-inch) with good linings (linings above .100 inch), the brake disc is considered below minimum wear thickness and should be replaced.

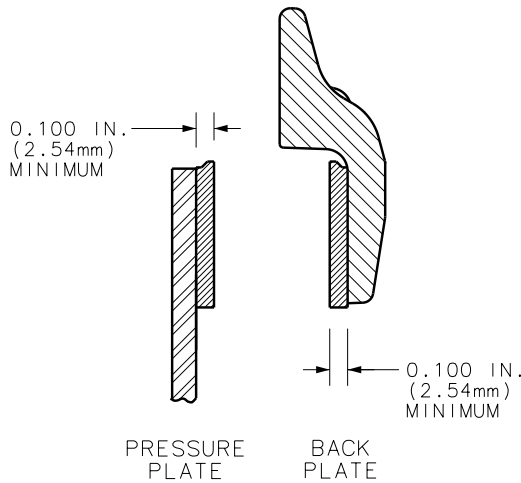

Figure A1  
Minimum Lining Thickness

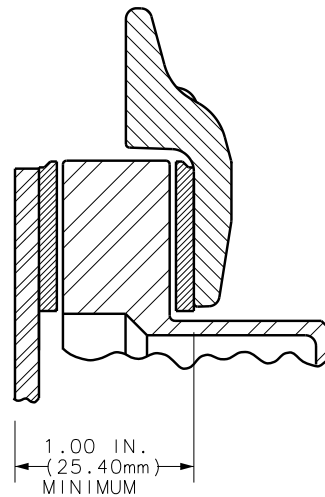

Figure A1-1  
Disc Wear Measurement  
(Piper Aztec)

**Wear Limits**

**A2. Brake Disc Minimum Thickness**

Under average field conditions a brake disc should give years of trouble free service. However, unimproved fields, standing water, heavy industrial pollution, or infrequent use of the aircraft may necessitate more frequent inspection of discs to prolong the life of the brake lining.

Generally the disc faces should be checked for wear (Figure A2 Dim. "A"), grooves, deep scratches, excessive general pitting or coning of the brake disc. Coning beyond 0.015 inch (0.381 mm) in either direction would be cause for replacement.

Single or isolated grooves up to 0.030 deep should not be cause for replacement, although general grooving of the disc faces will reduce lining life.

Discs are plated for special applications only, therefore, rust in varying degrees can occur. If a powder rust appears, one or two taxibraking applications should wipe the disc clear. Rust allowed to progress beyond this point, may require removal of the disc from wheel assembly to properly clean both faces. Wire brushing, followed by sanding with 220 grit sandpaper, can restore the braking surfaces for continued use.

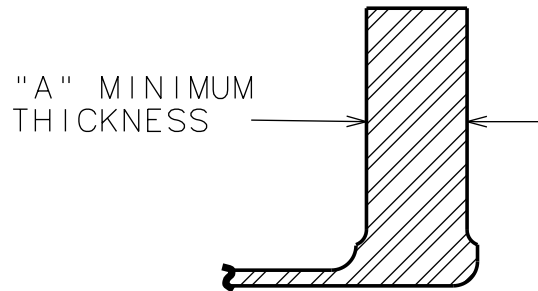

Figure A2 - Disc Thickness Measurement

## Wear Limits

## A2. Brake Disc Minimum Thickness (Cont'd)

Part Number	"A" in/mm	Part Number	"A" in/mm	Part Number	"A" in/mm	Part Number	"A" in/mm
159-00104	0.225/5.715	164-05606	0.395/10.033	164-17500	0.205/5.207	164-30414	0.325/8.255
159-00204	0.475/12.065	164-05700	0.525/13.335	164-18300	0.327/8.306	164-30440	0.190/4.826
164-00206	See Page A-1	164-05806	0.395/10.033	164-18800	0.190/4.826	164-30615-1	0.190/4.826
164-00300	0.205/5.207	164-06106	0.475/12.065	164-18900	0.330/8.382	164-30615-2	0.330/8.382
164-00400	0.162/4.115	164-06306	0.465/11.811	164-19000	0.330/8.382	164-30615-3	0.330/8.382
164-00500	0.157/3.988	164-06406	0.465/11.811	164-19200	0.191/4.826	164-30804-1	0.190/4.826
164-00700	0.345/8.763	164-06506	0.240/6.096	164-19300	0.190/4.826	164-30804-2	0.330/8.382
164-00806	0.334/8.484	164-06700	0.220/5.588	164-19400	0.190/4.826	164-30804-3	0.330/8.382
164-00900	0.227/5.766	164-06900	0.205/5.207	164-19500	0.325/8.255	464-11501	0.327/8.306
164-01000	0.345/8.763	164-07200	0.492/12.497	164-19600	0.325/8.255	464-11700	0.164/4.166
164-01100	0.345/8.763	164-07306	0.395/10.033	164-19700	0.325/8.255	464-12000	0.205/5.207
164-12000	0.205/5.207	164-07400	0.492/12.497	164-20100	0.250/6.350	464-12601	0.205/5.207
164-12601	0.205/5.207	164-07500	0.205/5.207	164-20206	0.334/8.484	464-13601	0.327/8.306
164-01300	0.227/5.764	164-07700	0.470/11.938	164-20306	0.465/11.811	464-14000	0.205/5.207
164-14000	0.205/5.207	164-07800	0.450/11.43	164-20500	0.525/13.335	464-14300	0.205/5.207
164-01406	0.334/8.484	164-07906	0.465/11.811	164-20600	0.455/11.557	464-17500	0.205/5.207
164-01501	0.327/8.306	164-08100	0.450/11.43	164-20700	0.410/10.414	464-18300	0.327/8.306
164-01506	0.327/8.306	164-08200	0.327/8.306	164-20806	0.475/12.065	564-02000	0.205/5.207
164-01600	0.157/3.988	164-08300	0.327/8.306	164-20900	0.410/10.414	564-04000	0.205/5.207
164-01700	0.167/4.242	164-08406	0.330/8.382	164-21000	0.436/11.074	564-21600	0.405/10.287
164-01900	0.227/5.766	164-08500	0.325/8.255	164-21100	0.492/12.497	564-22201	0.537/13.640
164-02000	0.205/5.207	164-08800	0.190/4.826	164-21200	0.327/8.306	564-22202	0.537/13.640
164-02201	0.345/8.763	164-08900	0.330/8.382	164-21406	0.334/8.484		
164-02300	0.345/8.763	164-09000	0.330/8.382	164-21600	0.405/10.287		
164-02501	0.445/11.303	164-09100	0.492/12.497	164-21700	0.475/12.065		
164-02502	0.445/11.303	164-09200	0.190/4.826	164-21900	0.590/14.986		
164-02503	0.445/11.303	164-09300	0.190/4.826	164-22000	0.360/9.144		
164-02504	0.445/11.303	164-09400	0.190/4.826	164-22201	0.537/13.640		
164-02505	0.445/11.303	164-09500	0.325/8.255	164-22202	0.537/13.640		
164-02601	0.205/5.207	164-09600	0.325/8.255	164-22400	0.385/9.779		
164-02700	0.330/8.382	164-09700	0.325/8.255	164-22900	0.410/10.414		
164-02701	0.340/8.636	164-09900	0.275/6.985	164-23000	0.565/14.351		
164-02706	0.330/8.382	164-10500	0.157/3.988	164-23001	0.582/14.783		
164-02707	0.330/8.382	164-10700	0.345/8.763	164-23002	0.582/14.783		
164-02800	0.227/5.766	164-10900	0.227/5.766	164-23100	0.345/8.763		
164-02900	0.580/14.732	164-11501	0.327/8.306	164-23300	0.475/12.065		
164-03006	0.282/7.163	164-11700	0.167/4.242	164-23400	0.205/5.207		
164-03106	0.163/4.140	164-11800	0.162/4.115	164-23600	0.190/4.826		
164-03206	See Page A-1	164-11900	0.227/5.766	164-23900	0.325/8.255		
164-03300	0.235/5.969	164-12000	0.205/5.207	164-24000	0.325/8.255		
164-03506	0.260/6.604	164-12300	0.345/8.763	164-24100	0.325/8.255		
164-03600	0.327/8.306	164-12501	0.445/11.303	164-24200	0.167/4.242		
164-03601	0.327/8.306	164-12502	0.445/11.303	164-24400	0.290/7.366		
164-03700	0.345/8.763	164-12504	0.445/11.303	164-24500	0.327/8.306		
164-03906	0.600/15.240	164-12505	0.445/11.303	164-24501	0.327/8.306		
164-04000	0.205/5.207	164-12601	0.205/5.207	164-24800	0.330/8.382		
164-04300	0.205/5.207	164-13300	0.235/5.969	164-25200	0.312/7.925		
164-04406	0.334/8.484	164-13600	0.327/8.306	164-25700	0.445/11.303		
164-04600	0.405/10.287	164-13601	0.327/8.306	164-25800	0.459/11.659		
164-04700	0.345/8.763	164-14000	0.205/5.207	164-30007	0.190/4.826		
164-04800	0.327/8.306	164-14300	0.205/5.207	164-30195	0.190/4.826		
164-05006	0.475/12.065	164-14800	0.327/8.306	164-30388	0.325/8.255		
164-05500	0.492/12.497	164-16700	0.220/5.588	164-30398	0.325/8.255		

**Torque Values****A3. Brake Assembly Back Plate Tie Bolt Torques**

A “D” shown adjacent to the torque value indicates the value to be a “Dry” torque only.

An “L” shown adjacent to the torque value indicates a “Lube” torque only. Lube requires the application of a thread lubricant to all friction surfaces of the hardware as shown in [Figure 312](#). Only use the thread lubricant specified for your brake assembly. A flag note will specify which thread lubricant to use.

**Caution:** DO NOT LUBRICATE ANY BOLT AND NUT COMBINATIONS THAT ARE SPECIFIED AS A “DRY” TORQUE VALUE.

**Note:** If there is any conflict or question regarding dry torque, torque requiring thread lubricant, or a torque value on your assembly, please contact Cleveland Customer Support for resolution.

Overtorquing (exceeding these values) could cause depressions in the brake cylinder, which result in dragging or bound up brakes. Use a torque wrench when installing back plate bolts to ensure the proper torquing values are attained. Replace the back plate bolts with approved bolts found at [clevelandwheelandbrake.com](http://clevelandwheelandbrake.com). Depressions in the brake cylinder (surface A) exceeding 0.005 inch (0.127 mm) deep require replacement of the brake cylinder.

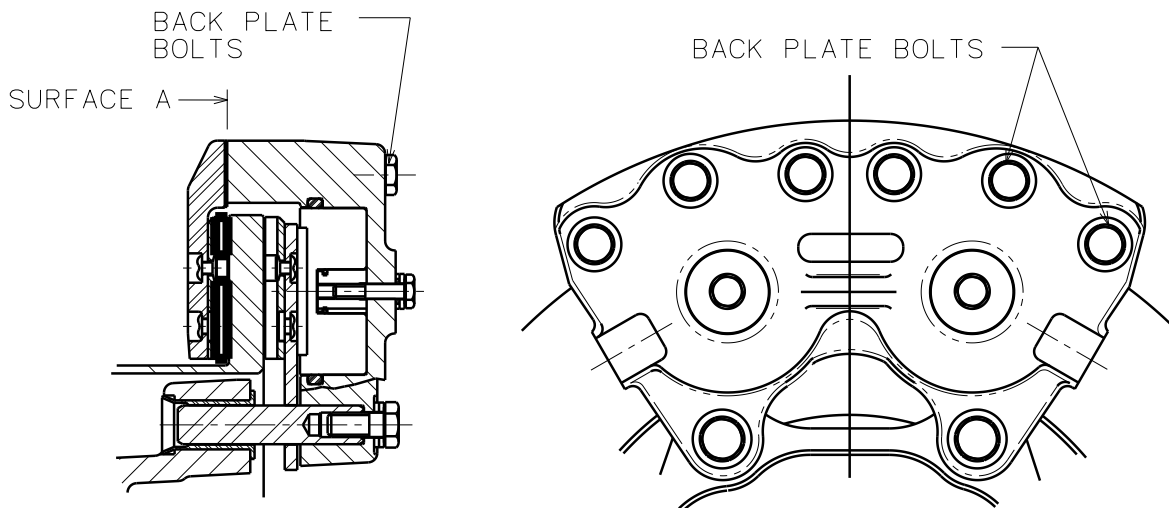

Figure A3 - Back Plate Bolts

**Table A3 Legend:**

Material Column: “A” Aluminum “M” Magnesium “S” Steel

(1) For assistance contact the Technical Services Hotline (see page 4).

Thread Lubricant:

(2) Use SAE AMS2518 (ref MIL-T-5544).

(3) Use MIL-PRF-83483 (Molydisulphide).

**Torque Values**

**A3. Brake Assembly Back Plate Tie Bolt Torques (Cont'd)**

Brake Assembly	Bolt Torque		Material	
	In-lb	N-M	Housing	Torque Pate
35-200A	60 D	6.8	A	S
30-4	60 D	6.8	A	S
30-5	60 D	6.8	A	S
30-6	60 D	6.8	A	S
30-7	60 D	6.8	A	S
37-200-2	90 D	10.2	A	S
30-9	75-80 D	8.5-9.0	A	S
30-9A	75-80 D	8.5-9.0	A	S
30-9C	75-80 D	8.5-9.0	A	S
30-9D	75-80 D	8.5-9.0	A	S
30-9E	75-80 D	8.5-9.0	A	S
3000-250	90 D	10.2	A	S
3000-500	90 D	10.2	A	S
30-18	75-80 D	8.5-9.0	A	S
30-19	75-80 D	8.5-9.0	A	S
30-19A	75-80 D	8.5-9.0	A	S
30-21	65-75 D	7.3-8.5	A	S
30-23	65-75 D	7.3-8.5	A	N/A
30-23A	65-75 D	7.3-8.5	A	N/A
30-23B	65-75 D	7.3-8.5	A	N/A
30-23C	65-75 D	7.3-8.5	A	N/A
30-23D	65-75 D	7.3-8.5	A	N/A
30-24	65-75 D	7.3-8.5	A	S
30-28B	80-90 D	9.0-10.2	M	M
30-28C	80-90 D	9.0-10.2	M	M
30-28D	80-90 D	9.0-10.2	M	M
30-30	90 D	10.2	M	S
30-31	1/4-28 85-90 D 3/8-24 125-150 D	9.6-10.2 14.0-17.0	A	S
30-32	65-75 D	7.3-8.5	A	S
30-32A	65-75 D	7.3-8.5	A	S
30-32B	65-75 D	7.3-8.5	A	S
30-32C	65-75 D	7.3-8.5	A	S
30-32E	65-75 D	7.3-8.5	A	S
30-35	65-75 D	7.3-8.5	A	S
30-40	60 D	6.8	A	S
30-40A	75-80 D	8.5-9.0	A	S
30-41	65-75 D	7.3-8.5	A	N/A
30-41A	90 D	10.2	A	S
30-41B	65-75 D	7.3-8.5	A	N/A
30-45	60 D	6.8	A	S
30-51	65-75 D	7.3-8.5	A	S
30-51A	65-75 D	7.3-8.5	A	S
30-51B	65-75 D	7.3-8.5	A	S
30-52	90 D	10.2	M	S
30-52A	90 D	10.2	M	S
30-52B	90 D	10.2	M	S
30-52D	90 D	10.2	M	S
30-52E	90 D	10.2	M	S
30-52F	90 D	10.2	M	S
30-52G	90 D	10.2	M	S
30-52H	90 D	10.2	M	S
30-52K	90 D	10.2	M	S

Brake Assembly	Bolt Torque		Material	
	In-lb	N-M	Housing	Torque Pate
30-52L	75-80 D	8.5-9.0	M	N/A
30-52M	90 D	10.2	M	S
30-52N	90 D	10.2	M	S
30-52P	90 D	10.2	M	S
30-52Q	90 D	10.2	M	S
30-52S	90 D	10.2	M	S
30-52T	90 D	10.2	M	S
30-52U	90 D	10.2	M	S
30-52V	90 D	10.2	M	S
30-52W	90 D	10.2	M	S
30-52X	90 D	10.2	M	S
30-52Y	90 D	10.2	A	S
30-52Z	90 D	10.2	M	S
30-52AA	90 D	10.2	M	S
30-52AB	90 D	10.2	M	S
30-52AC	90 D	10.2	M	S
30-53	75-80 D	8.5-9.0	M	S
30-53A	75-80 D	8.5-9.0	M	S
30-54	90 D	10.2	M	A
30-54A	90 D	10.2	M	A
30-54B	90 D	10.2	M	S
30-54C	85-90 D	9.6-10.2	M	A
30-55	75-80 D	8.5-9.0	M	S
30-55A	75-80 D	8.5-9.0	(1)	(1)
30-55B	75-80 D	8.5-9.0	M	S
30-56	75-80 D	8.5-9.0	M	S
30-56A	75-80 D	8.5-9.0	M	S
30-56B	75-80 D	8.5-9.0	M	S
30-56C	75-80 D	8.5-9.0	M	S
30-56D	75-80 D	8.5-9.0	M	S
30-56F	75-80 D	8.5-9.0	M	S
30-58A	75-80 D	8.5-9.0	(1)	(1)
30-58B	75-80 D	8.5-9.0	M	(1)
30-59	75-80 D	8.5-9.0	M	S
30-59A	75-80 D	8.5-9.0	M	S
30-59D	75-80 D	8.5-9.0	M	S
30-59E	75-80 D	8.5-9.0	M	S
30-60	75-80 D	8.5-9.0	A	S
30-60A	65-75 D	7.3-8.5	A	S
30-60B	65-75 D	7.3-8.5	A	S
30-61	90 D	10.2	M	S
30-61A	90 D	10.2	M	S
30-61B	65-75 D	7.3-8.5	M	S
30-61D	90 D	10.2	M	S
30-61E	90 D	10.2	M	S
30-61F	90 D	10.2	M	S
30-63	75-80 D	8.5-9.0	M	S
30-63A	75-80 D	8.5-9.0	M	S
30-63B	75-80 D	8.5-9.0	M	S
30-63D	75-80 D	8.5-9.0	M	S
30-63E	75-80 D	8.5-9.0	M	S
30-63F	75-80 D	8.5-9.0	M	S
30-63J	75-80 D	8.5-9.0	M	S
30-63K	75-80 D	8.5-9.0	M	S
30-63M	75-80 D	8.5-9.0	M	S

## Torque Values

## A3. Brake Assembly Back Plate Tie Bolt Torques (Cont'd)

Brake Assembly	Bolt Torque		Material		Brake Assembly	Bolt Torque		Material	
	In-lb	N-M	Housing	Torque Pate		In-lb	N-M	Housing	Torque Pate
30-63P	75-80 D	8.5-9.0	M	S	30-97	80-90 D	9.0-10.2	A	M
30-63Q	75-80 D	8.5-9.0	M	S	30-98	80-90 D	9.0-10.2	A	A
30-63S	75-80 D	8.5-9.0	M	S	30-98A	80-90 D	9.0-10.2	A	A
30-65	75-90 D	8.5-10.2	M	S	30-98B	80-90 D	9.0-10.2	A	A
30-65A	75-90 D	8.5-10.2	M	S	30-98C	80-90 D	9.0-10.2	A	A
30-65E	75-90 D	8.5-10.2	M	S	30-98D	80-90 D	9.0-10.2	A	A
30-66	90 D	10.2	M	A	30-99	75-80 D	8.5-9.0	M	A
30-66A	90 D	10.2	M	M	30-99A	75-80 D	8.5-9.0	M	M
30-66B	90 D	10.2	M	A	30-100	75-80 D	8.5-9.0	M	M
30-66C	90 D	10.2	M	A	30-106	80-90 D	9.0-10.2	M	M
30-66D	90 D	10.2	M	(1)	30-107	85-90 D	9.6-10.2	A	M
30-66F	90 D	10.2	M	M	30-107A	85-90 D	9.6-10.2	A	M
30-66G	80-90 D	9.0-10.2	M	A	30-107B	85-90 D	9.6-10.2	A	M
30-66H	75-90 D	8.5-10.2	M	S	30-107C	85-90 D	9.6-10.2	A	M
30-67	85-90 D	9.6-10.2	A	A	30-107D	85-90 D	9.6-10.2	A	M
30-67A	85-90 D	9.6-10.2	A	A	30-107E	80-95 D	9.0-10.7	A	M
30-67B	85-90 D	9.6-10.2	A	A	30-111	80-90 D	9.0-10.2	A	A
30-67C	85-90 D	9.6-10.2	A	A	30-113	80-90 D	9.0-10.2	A	M
30-67D	85-90 D	9.6-10.2	A	A	30-113A	80-90 D	9.0-10.2	A	M
30-67E	85-90 D	9.6-10.2	A	A	30-123	80-90 D	9.0-10.2	M	M
30-67X	85-90 D	9.6-10.2	A	A	30-127	90 D	10.2	M	S
30-68	75-80 D	8.5-9.0	M	M	30-127A	90 D	10.2	M	S
30-68A	75-80 D	8.5-9.0	M	M	30-127C	90 D	10.2	M	S
30-68B	75-80 D	8.5-9.0	M	M	30-127D	90 D	10.2	M	S
30-69A	85-95 D	9.6-10.7	M	M	30-129	75-90 D	8.5-10.2	M	S
30-69B	90 D	10.2	M	M	30-131	80-90 D	9.0-10.2	A	M
37-200A	65-70 D	7.3-7.9	A	S	30-133	75-80 D	8.5-9.0	M	S
30-74B	60-75 D	6.8-8.5	M	M	30-138	80-90 D	9.0-10.2	M	M
30-75	75-80 D	8.5-9.0	A	S	30-139	75-80 D	8.5-9.0	M	S
30-75A	75-80 D	8.5-9.0	A	S	30-141	150 D	16.9	A	M
30-75B	75-80 D	8.5-9.0	A	S	30-142	150 D	16.9	A	M
30-75X	75-80 D	8.5-9.0	A	S	30-143	150 D	16.9	A	M
30-79	90 D	10.2	A	S	30-144	85-90 D	9.6-10.2	A	M
30-79A	90 D	10.2	A	S	30-144A	85-90 D	9.6-10.2	A	M
30-79B	90 D	10.2	A	S	30-144B	85-90 D	9.6-10.2	A	M
30-83	90 D	10.2	M	S	30-145	80-90 D	9.0-10.2	M	M
30-83A	90 D	10.2	M	S	30-146	85-90 D	9.6-10.2	A	M
30-84	80-90 D	9.0-10.2	A	N/A	30-146A	85-90 D	9.6-10.2	A	A
30-88	75-80 D	8.5-9.0	M	A	30-149	80-90 D	9.0-10.2	A	A
30-89	80-90 D	9.0-10.2	A	A	30-158	80-90 D	9.0-10.2	M	M
30-89A	80-90 D	9.0-10.2	A	A	30-159	85-90 D	9.6-10.2	A	M
30-89B	80-90 D	9.0-10.2	A	A	30-159A	85-90 D	9.6-10.2	A	M
30-89C	80-90 D	9.0-10.2	A	A	30-159B	85-90 D	9.6-10.2	A	M
30-89E	80-90 D	9.0-10.2	A	A	30-159C	85-90 D	9.6-10.2	A	M
30-93	80-90 D	9.0-10.2	M	M	30-163	85-90 D	9.6-10.2	M	A
30-93A	80-90 D	9.0-10.2	M	M	30-164	75-80 D	8.5-9.0	M	S
30-93B	80-90 D	9.0-10.2	M	M	30-170	80-85 D	9.0-9.6	A	A
30-93C	80-90 D	9.0-10.2	M	M	30-176	85-90 D	9.6-10.2	A	A
30-93D	80-90 D	9.0-10.2	M	M	30-181A	75-80 D	8.5-9.0	A	S
30-93E	90-100 D	10.2-11.3	M	M	30-182	85-90 D	9.6-10.2	M	A
30-94	80-90 D	9.0-10.2	A	A	30-182A	85-90 D	9.6-10.2	M	A
30-95	60 D	6.8	(1)	(1)	30-184	80-90 D	9.0-10.2	A	A
30-95A	60 D	6.8	M	M	30-195	85-90 D	9.6-10.2	A	A
30-95B	60 D	6.8	M	M	30-195A	85-90 D	9.6-10.2	A	A
30-96	60 D	6.8	M	S	30-210	80-85 L (2)	9.0-9.6	A	A

**Torque Values****A3. Brake Assembly Back Plate Tie Bolt Torques (Cont'd)**

Brake Assembly	Bolt Torque		Material	
	In-lb	N-M	Housing	Torque Pate
30-210A	80-85 L (3)	9.0-9.6	A	A
30-210C	80-85 L (3)	9.0-9.6	A	A
30-214	75-80 D	8.5-9.0	M	S
30-214B	75-80 D	8.5-9.0	M	S
30-220	85-90 D	9.6-10.2	A	M
30-224	75-80 D	8.5-9.0	M	S
30-231	80-90 D	9.0-10.2	A	A
30-233	90 D	10.2	M	S
30-233A	90 D	10.2	M	S
30-233B	90 D	10.2	M	S
30-233C	90 D	10.2	M	S
30-233E	85-95 D	9.6-10.7	M	S
30-233E RH	85-95 D	9.6-10.7	M	S
30-236	75-80 D	8.5-9.0	M	N/A
30-239	75-80 D	8.5-9.0	M	S
30-239A	75-80 D	8.5-9.0	M	S
30-239B	75-80 D	8.5-9.0	A	S
30-241	90 L (3)	10.2	A	S
30-269	90 D	10.2	M	A
30-280	85-90 D	9.6-10.2	A	A
30-290	85-90 D	9.6-10.2	A	S
30-293	85-90 D	9.6-10.2	A	S
30-293 RH	85-90 D	9.6-10.2	A	S
30-308	75-80 D	8.5-9.0	M	S
30-312	85-90 D	9.6-10.2	A	S
C-30018	120-130 D	13.6-14.7	A	S
C-30018-1	120-130 D	13.6-14.7	A	S
C-30018-2	120-130 D	13.6-14.7	A	S
C-30018-3	120-130 D	13.6-14.7	A	S
C-30018-4	120-130 D	13.6-14.7	A	S
C-30018-5	120-130 D	13.6-14.7	A	S
C-30018-6	120-130 D	13.6-14.7	A	S
C-30018-7	120-130 D	13.6-14.7	A	S
D-30118-3	100-110 D	11.3-12.4	A	S
D-30118-4	100-110 D	11.3-12.4	A	S
D-30118-5	100-110 D	11.3-12.4	A	S
D-30118-6	100-110 D	11.3-12.4	A	S
D-30118-7	100-110 D	11.3-12.4	A	S
D-30118-8	100-110 D	11.3-12.4	A	S
D-30118-9	100-110 D	11.3-12.4	A	S
D-30118-10	100-110 D	11.3-12.4	A	S
C-30764-5	120-130 D	13.6-14.7	A	S
C-30764-6	120-130 D	13.6-14.7	A	S
C-30764-7	120-130 D	13.6-14.7	A	S
D-30793-3	100-110 D	11.3-12.4	A	S
D-30793-4	100-110 D	11.3-12.4	A	S
D-30793-5	100-110 D	11.3-12.4	A	S
D-30793-6	100-110 D	11.3-12.4	A	S

**Torque Values**

**A4. Wheel Assembly Torque Values**

All wheel assembly tie bolt and nut torque values listed are to be applied to the nut only.

A “**D**” shown adjacent to the torque value indicates the value to be a “**Dry**” torque only.

An “**L**” shown adjacent to the torque value indicates a “**Lube**” torque only. Lube requires the application of a thread lubricant to all friction surfaces of the hardware as shown in [Figure 312](#). Only use the thread lubricant specified for your wheel assembly. A flag note will specify which thread lubricant to use.

**CAUTION:** DO NOT LUBRICATE ANY BOLT AND NUT COMBINATIONS THAT ARE SPECIFIED AS A “DRY” TORQUE VALUE.

**Note:** If there is any conflict or question regarding dry torque, torque requiring thread lubricant, or a torque value on your assembly, please contact Cleveland Customer Support for resolution.

[A5-#] = Code for inflation valve stem torque. See appropriate dash number, #-#, in Table A5 for torque value.

**Table A4 Legend:**

Material Column: “**A**” Aluminum “**M**” Magnesium

(1) For assistance contact the Technical Services Hotline (see page 4).

Thread Lubricant:

(2) Use SAE AMS2518 (ref MIL-T-5544). (3) Use MIL-PRF-83483 (Molydisulphide).

Wheel Bearing Grease: ([Refer to Section 300, paragraph 3.A. Bearing Grease](#))

All active wheel assemblies listed are shipped with Mobil Aviation Grease SHC 100 except:

- (4) Wheel uses BG Products HCF Grease P/N 605 (Amphibious).
- (8) Wheel uses OMNI Waterproof Green Grease, No. 2 (Amphibious).
- (9) Wheel uses Mobil Aviation Grease SHC 100 ONLY.

Torque Values:

- (5) Dry torque brake disc bolts to 80 in-lbs.
- (6) Dry torque brake disc bolts to 150 in-lbs.
- (7) Torque value is dependent on hardware configuration. PRM’s are in development to release the hardware upgrade for the following assemblies. In the interim, follow the wheel assembly nameplate for torque value. The table below is for reference only. For assistance contact the Technical Services Hotline (see page 4).

Wheel Assembly	Nut / Washer	Torque in-lb. (N-M)
40-87C, 40-110, 40-168	094-01200 / 095-10400	75 D (8.5)
	094-10300 / 095-10200	90 D (10.2)
40-87	094-01200 / 095-10400 (qty 6)	75 D (8.5)
	094-10300 / 095-10400 (qty 3)	90 D (10.2)
40-151, 40-151A, 40-230	094-01200 / 095-10200	75 D (8.5)
	094-10300 / 095-10200	90 D (10.2)
40-87A, 40-87D, 40-87F, 40-110B, 40-152	094-01200 / 095-10400	75 D (8.5)
	094-10300 / 095-10400	90 D (10.2)

**Torque Values**

**A4. Wheel Assembly Bolt Torques**

Wheel Assembly	Bolt Torque		Material Wheel
	In-lb	N-M	
27-100D	90 D	10.2	A
21-100D	90 D	10.2	M
3080A	90 D	10.2	M
3080B	90 D	10.2	M
3070	90 D	10.2	M
3040	90 D	10.2	A
3050	90 D	10.2	A
3050A	90 D	10.2	A
38501	90 D	10.2	M
40-12	90 D	10.2	M
40-12A	90 D	10.2	M
40-18	90 D	10.2	M
40-19	90 D	10.2	A
40-19A	90 D	10.2	A
40-21	90 D	10.2	A
40-24	90 D	10.2	A
40-28	90 D	10.2	M
40-28D	90 D	10.2	M
40-30A	90 D	10.2	A
40-32	90 D	10.2	A
40-34	90 D	10.2	M
40-37	90 D	10.2	A
40-40A	135-145D	15.3-16.4	M
40-40B	135-145D	15.3-16.4	M
40-40C	90 D	10.2	M
40-40D	150 D	16.9	M
40-41	150 D	16.9	M
40-46	90 D	10.2	A
40-47	150 D	16.9	A
40-50	90 D	10.2	A
40-55	90 D	10.2	A
40-56	150 D	16.9	M
40-56B	150 D	16.9	M
40-56C	150 D	16.9	M
40-57	90 D	10.2	A
40-57A	90 D	10.2	A
40-58	90 D	10.2	M
40-59	150 D	16.9	M
40-59A	150 D	16.9	M
40-59B	150 D	16.9	M
40-59D	150 D	16.9	M
40-59E	150 D	16.9	M
40-60	90 D	10.2	M
40-60A	90 D	10.2	A
40-61	90 D	10.2	M
40-66	90 D	10.2	A
40-74	90 D	10.2	A
40-74A	90 D	10.2	A
40-74B	90 D	10.2	A
40-75B	150 D	16.9	M
40-75D	150 D	16.9	M
40-75E	150 D	16.9	M
40-75F	150 D	16.9	M
40-75G	150 D	16.9	M
40-75H	150 D	16.9	M
40-75J	150 D	16.9	M

Wheel Assembly	Bolt Torque		Material Wheel
	In-lb	N-M	
40-75P	150 D	16.9	M
40-75S	150 D	16.9	M
40-75T	150 D	16.9	M
40-75W	150 D	16.9	M
40-75Z	150 D	16.9	M
40-75AA	150 D	16.9	M
40-76A	150 D	16.9	M
40-76B	150 D	16.9	M
40-76C	150 D	16.9	M
40-76D	150 D	16.9	M
40-76E	150 D	16.9	M
40-76F	150 D	16.9	M
40-76G	150 D	16.9	M
40-76H	150 D	16.9	M
40-76P	150 D	16.9	M
40-76-1	150 D	16.9	(1)
40-77	Refer to PRM86		M
40-77A	Refer to PRM94		M
40-77B	Refer to PRM94		M
40-77C	Refer to PRM83		M
40-77D	90 D	10.2	M
40-77E	Refer to PRM83		M
40-77F	Refer to PRM94		M
40-77G	90 L (2)	10.2	M
40-77H	90-100 L (2)	10.2-11.3	M
40-78	Refer to PRM96		M
40-78A	Refer to PRM96		A
40-78B	Refer to PRM96		M
40-78E	Refer to PRM96		M
40-78J	Refer to PRM96		A
40-79A	150 D	16.9	M
40-83	150 D	16.9	M
40-83A	150 D	16.9	M
40-83B	150 D	16.9	M
40-84	150 D	16.9	M
40-84A	150 D	16.9	M
40-84B	150 D	16.9	M
40-86	150 D	16.9	M
40-86A	150 D	16.9	M
40-86B	150 D	16.9	M
40-86E	150 D	16.9	M
40-86F	150 D	16.9	M
40-87	(7)		M
40-87A	(7)		M
40-87C	(7)		A
40-87D	(7)		M
40-87F	(7)		M
40-87G	115-135 D	13.0-15.3	M
40-87H	75 D	8.5	A
40-87J (8)	75 D	8.5	A
40-87K (4)	75 D	8.5	A
40-88C	150 D	16.9	M
40-90	150 D	16.9	M
40-90A	150 D	16.9	M
40-90B	150 D	16.9	M
40-90D	150 D	16.9	M

**Torque Values**

**A4. Wheel Assembly Bolt Torques (Cont'd)**

Wheel Assembly	Bolt Torque		Material Wheel
	In-lb	N-M	
40-90E	150 D	16.9	M
40-90F	150 D	16.9	M
40-96E	150 D	16.9	M
40-97A	150 D	16.9	M
40-97B	150 D	16.9	M
40-97C	150 D	16.9	M
40-97D	150 D	16.9	M
40-97E	150 D	16.9	M
40-97F	150 D	16.9	M
40-98	150 D	16.9	M
40-98A	150 D	16.9	M
40-98D	150 D	16.9	M
40-98E	150 D	16.9	M
40-98F	150 D	16.9	M
40-98G	150 D	16.9	M
40-98H	150 D	16.9	M
40-98N	150 D	16.9	M
40-98P	150 D	16.9	M
40-99	90 D	10.2	M
40-101	90 D	10.2	A
40-101A	90 D	10.2	A
40-101D	90 D	10.2	A
40-101E	90 D	10.2	A
40-101F (8)	90 D	10.2	A
40-101G (4)	90 D	10.2	A
40-102	90 D	10.2	M
40-102A	90 D	10.2	M
40-103	90 D	10.2	A
40-103A	90 D	10.2	A
40-106	150 D	16.9	M
40-106A	150 D	16.9	M
40-107A [A5-3]	300 L (2)	33.9	M
40-110		(7)	M
40-110B		(7)	M
40-111	150 D	16.9	M
40-111A	150 D	16.9	M
40-112	90 D	10.2	A
40-113	90 D	10.2	A
40-113A	90 D	10.2	A
40-113B	90 D	10.2	A
40-113C	90 D	10.2	A
40-113X	90 D	10.2	A
40-115	90 D	10.2	M
40-115A	115-135 D	13.0-15.3	M
40-115B	115-135 D	13.0-15.3	M
40-115C	115-135 D	13.0-15.3	M
3080D (5)	90 D	10.2	M
40-117A	150 D	16.9	M
40-120	150 D	16.9	M
40-120A	150 D	16.9	M
40-120C	150 D	16.9	M
40-124	180 D	20.3	M
40-127	300 L (2)	33.9	A
40-128	180 D	20.3	M
40-128A	180 D	20.3	M
40-128C	180 D	20.3	M

Wheel Assembly	Bolt Torque		Material Wheel
	In-lb	N-M	
40-128D	180 D	20.3	M
40-128E	180 D	20.3	M
40-129	90 D	10.2	A
40-130	90 D	10.2	M
40-131 (5)	90 D	10.2	M
40-132 [A5-1]	150 D	16.9	M
40-133	150 D	16.9	A
40-134 [A5-2]	150 D	16.9	M
40-134A [A5-2]	150 D	16.9	M
40-135	135-145 D	15.3-16.4	M
40-135A	150 D	16.9	M
40-135B	150 D	16.9	M
40-137	180 D	20.3	A
40-138A	150 D	16.9	M
40-138B	150 D	16.9	M
40-138C	180 D	20.3	M
40-139	150 D	16.9	A
40-140	150 D	16.9	M
40-140A	150 D	16.9	M
40-140B	150 D	16.9	M
40-140C	150 D	16.9	M
40-141	150 D	16.9	M
40-142	150 D	16.9	M
40-142A	150 D	16.9	M
40-143	150 D	16.9	M
40-148 [A5-3]	300 D	33.9	M
40-151		(7)	M
40-151A		(7)	A
40-152		(7)	M
40-162	150 D	16.9	M
40-163	150 D	16.9	M
40-166 [A5-1] (6)	300 D	33.9	M
40-167 (6)	300 D	33.9	M
40-168		(7)	A
40-169 [A5-1] (6)	150 D	16.9	M
40-170 [A5-3]	300 L (2)	33.9	M
40-170A [A5-3]	300 L (2)	33.9	A
40-170B [A5-3]	300 L (2)	33.9	M
40-171	180 D	20.3	M
40-172	180 D	20.3	M
40-174	300 L (2)	33.9	A
40-175	150 D	16.9	A
40-176 [A5-1]	300 D	33.9	A
40-176A [A5-1]	300 D	33.9	A
40-177A (9)	150 D	16.9	M
40-179 (9)	150 D	16.9	A
40-179A	150 D	16.9	A
40-181B [A5-1]	180 D	20.3	A
40-181C [A5-1]	180 D	20.3	A
40-193	150 D	16.9	A
40-195	150 D	16.9	M
40-196	90 D	10.2	M
40-198 [A5-3]	300 L (2)	33.9	M
40-199	90 D	10.2	A
40-199A	90 D	10.2	A
40-202 [A5-1]	300 L (2)	33.9	A

## Torque Values

## A4. Wheel Assembly Bolt Torques (Cont'd)

Wheel Assembly	Bolt Torque		Material Wheel
	In-lb	N-M	
40-203 [A5-4]	290-300 L (2)	32.8-33.9	A
40-204 [A5-4]	290-300 L (2)	32.8-33.9	A
40-205 [A5-1]	180 D	20.3	M
40-210 [A5-6]	150 L (2)	16.9	M
40-211 [A5-3]	300 D	33.9	M
040-21101 [A5-3]	300 L (2)	33.9	M
40-212 [A5-1]	150 L (2)	16.9	M
40-223	90 D	10.2	A
40-230		(7)	M
40-234	90 D	10.2	A
40-239 [A5-6]	300 L (2)	33.9	A
040-23901 [A5-6]	300 L (2)	33.9	A
40-240A [A5-6]	125 L (2)	14.1	M
40-255 [A5-1]	90-100 L (2)	10.2-11.3	M
40-256	135-145 D	15.3-16.4	M
40-258	300 D	33.9	(1)
40-259 [A5-1]	95-105 L (2)	10.7-11.8	M
40-260 [A5-1]	95-105 L (2)	10.7-11.8	M
40-262A [A5-6]	90 L (2)	10.2	M
40-262AA [A5-6]	90 L (2)	10.2	M
40-270 [A5-6]	115-135 L (2)	13.0-15.3	M
40-273 [A5-5]	300 L (2)	33.9	A
40-273A [A5-4]	290-300 L (2)	32.8-33.9	A
40-273B [A5-4]	290-300 L (2)	32.8-33.9	A
40-276 [A5-6]	90-100 L (2)	10.2-11.3	M
40-279 [A5-3]	300 L (2)	33.9	M
40-279A [A5-3]	300 L (3)	33.9	M
40-281	90 D	10.2	M
40-289 [A5-1]	300 L (2)	33.9	A
40-293 [A5-6]	180-190 L (2)	20.3-21.5	A
40-307	75 D	8.5	M
40-308	75 D	8.5	M
40-403	150 D	16.9	A
40-406	150 D	16.9	M
40-406A	150 D	16.9	M
40-406B	150 D	16.9	M
40-406C	150 D	16.9	M
40-406D	150 D	16.9	M
40-407	150 D	16.9	M
40-414	150 D	16.9	M
40-414A	150 D	16.9	M
40-417 [A5-7]	115-125 L (3)	12.9-14.1	A
40-418 (4)	150 D	16.9	A
40-418A (4)	150 D	16.9	A
40-418B (8)	150 D	16.9	A
40-418C (4)	150 D	16.9	A
40-418D (4)	150 D	16.9	A
40-423 [A5-8]	170-190 L (3)	19.2-21.5	A
40-426 (4)	150 D	16.9	A
40-426A (8)	150 D	16.9	A
40-426B	150 D	16.9	A
40-426C	150 D	16.9	A
40-426D (4)	150 D	16.9	A
40-432 [A5-1]	115-125 L (3)	13.0-14.1	A
40-434 [A5-6]	315-325 L (3)	35.6-36.7	A
40-450	105-115 L (2)	11.9-13.0	A

Wheel Assembly	Bolt Torque		Material Wheel
	In-lb	N-M	
40-455	150 D	16.9	A
40-459	150 D	16.9	M
040-46900 [A5-1]	115-125 L (3)	13.0-14.1	M
40-481 [A5-1]	290-300 L (2)	32.8-33.9	A
40-483 [A5-1]	290-300 L (3)	32.8-33.9	M
C-30174-1	95 D	10.7	(1)
C-30179	190-200 D	21.5-22.6	(1)
D-30204	95 D	10.7	(1)
D-30255	195 D	22.0	(1)
D-30260	195 D	22.0	(1)
D-30260-1	195 D	22.0	(1)
D-30291-1	195 D	22.0	A
D-30291-2	195 D	22.0	A
D-30291-3	195 D	22.0	A
D-30291-4	195 D	22.0	A
D-30291-5	195 D	22.0	A
D-30291-6	195 D	22.0	A
D-30380	95 D	10.7	A
C-30480	195 D	22.0	(1)
D-30500	145 D	16.4	A
D-30500-1	145 D	16.4	A
D-30570	195 D	22.0	A
D-30580	195 D	22.0	(1)
D-30585	195 D	22.0	(1)
D-30660-1	145 D	16.4	A
D-30660-2	145 D	16.4	A
D-30660-3	145 D	16.4	A
D-30660-4	145 D	16.4	A
D-30660-5	145 D	16.4	A
D-30660-6	145 D	16.4	A
D-30660-7	145 D	16.4	A
D-30660-8	145 D	16.4	A
D-30660-9	145 D	16.4	A
D-30660-10	145 D	16.4	A
D-30665	145 D	16.4	A
D-30665-1	145 D	16.4	A

## A5. Tire Inflation Valve Stem Torques

Inflation Valve Code Dash No. [A5-#]	Inflation Valve P/N	Recommended Torque	
		In-lb	N-M
A5-1	160-00700	50-60	5.7-6.8
A5-2	160-00900	165-200	18.7-22.6
A5-3	160-01100	75-100	8.4-11.3
A5-4	160-01200	35-45	4.0-5.1
A5-5	160-01500	70-80	7.9-9.0
A5-6	160-01900	50-60	5.7-6.8
A5-7	160-02000	25-35	2.8-3.9
A5-8	160-01900	45-55	5.08-6.21



**B1. Special Tools**

Item	Part Number	Description
O-Ring Extractor Kit	199-18	Consists of multi-hook, multi-ramp, and case.
Brake Line Bleeder	087-00500	The brake line bleeder can be used to service all Cleveland Products hydraulic brake assemblies or any other brake assembly utilizing the 079-00300 (FC-6446) bleeder screw.

**B2. Lubricants For Elastomeric Compounds**

Pneumatic Applications:

Grease per MIL-G-4343:

Royco 43 – Royal Lubricants Co., Inc., East Hanover, NJ

Aeroshell 43 – Royal Lubricants Co., Inc., East Hanover, NJ

Cosmolube 615 – Houghton International, Inc., Fogelsville, PA

Other:

55 O-Ring Lubricant – Dow Corning Corp., Midland, MI

Hydraulic Applications – Use fluids compatible with the system

MIL-H-5606 / MIL-H-83282 (Red Oils)

Skydrol – Only compatible with itself.

**B3. Lubricants**

Wheel Bearing Grease – [Refer to Section 300, paragraph 3.A. Bearing Grease](#)

MIL-PRF-81322, Grade 2 or DOD-G-24508A

(Aeroshell Grease 22) Shell Oil Company, Metairie, LA

(Mobilgrease 28) ExxonMobil Corp., Spring, TX

(Royco 22CF) Lanxess, Pittsburgh, PA

Mobil Aviation Grease SHC 100

ExxonMobil Oil Corp., Beaumont, TX

HCF Grease P/N 605 (Amphibious)

BG Products, Wichita, KS

OMNI Waterproof Green Grease, No. 2

OMNI Lubricants, Lewisville, TX

SAE AMS3058

(NYCO Grease GN 3058) NYCO, Paris, France

(Aeroshell Grease 58) Shell Oil Company, Metairie, LA

Bolts/Nuts Thread Lubricant -- Only use the thread lubricant specified for your assembly per SAE AMS2518 (ref MIL-T-5544)

Armite Laboratories, Costa Mesa, CA

Royco 44 – Royal Lubricant, East Hanover, NJ

per MIL-PRF-83483 (Molydisulphide)

Moly-50 P/N 51094 – Fel-Pro Chemical Products L.P., Skokie, IL

Pipe Threads (Brake Cylinder Inlet Fittings) - Apply to First 3 Threads

Lubon #404EU - Oil Center Research (Balmar LLC), Lafayette, LA

Loctite 567 Thread Sealant - Henkel Corp., Rocky Hill, CT

Loctite 592 Thread Sealant w/ PTFE - Henkel Corp., Rocky Hill, CT

PPG JC5A Jointing Compound - PPG Aerospace PRC-DeSoto, Sylmar, CA

**B3. Lubricants (Cont'd)**

Anchor Bolts/Torque Plate Bushings

Amphibious Environment

Lubriplate X-357 Extreme Pressure Moly Lubricant

Non-Amphibious Environment

Silicone Spray

Dri-Slide® Multi-Purpose Lubricant

LPS Force 842® Dry Moly Lubricant

**B4. Surface Repair**

Aluminum: Conversion Coating per MIL-C-5541, Class 1A, (Alodine)

Magnesium:

For parts surface pretreated per AMS-M-3171 (MIL-M-3171) (dull bronze to bright gold appearance)

- Surface pretreatment per AMS-M-3171 (MIL-M-3171)  
Type III (dip), Type VI (brush on), or Type VIII (dip)
- IRIDITE 15, MacDermid Inc., Waterbury, CT (800) 325-4158  
(use instructions furnished by Mfr. for AZ81 & AZ91 magnesium)

For parts pretreated with Oxsilan® (clear to iridescent appearance)

- Oxsilan® MG 0610, Chemetall Oakite, [www.chemetall.com](http://www.chemetall.com)

**B5. Primers and Paints**

Color	Sherwin Williams, Cleveland, OH <a href="http://www.sherwin-williams.com">www.sherwin-williams.com</a>
White Paint	Primer: P60G2, P60G10, or PSE2130-WHITE Topcoat: F63W13 (White)
Silver Paint	Primer: P60G2, P60G10, or PSE2130-WHITE Topcoat: F63BXS58-4337 (Silver)
Silver Paint (brake discs)	Primer: P60G2, P60G10, or PSE2130-WHITE Topcoat: F63BXS58-4337 (Silver)

ZRC Products [www.zrcworldwide.com](http://www.zrcworldwide.com)

- ZRC Galvilit Cold Galvanizing Compound (per MIL-PRF-26915A)

**NOTE:** Coatings other than those listed in this component maintenance manual may be used provided the coatings comply with the coating thickness and cure temperature limitations. Cleveland Wheel & Brake Systems is not responsible for the performance of coatings not listed in this component manual. Consult your local EPA regulations prior to using coatings not listed in this component maintenance manual.

**B6. Chemical Stripping Agents**

For Magnesium alloys AZ81 and AZ91

Turco Products

- Spray or brush on application:  
Water Based Environmentally Advantaged Paint Remover P/N T-6813 or T-6840S
- Tank type stripping application:  
Diphase Hot Tank Paint Remover P/N T-5668

**Brake Assembly / Lining Cross-Reference****External Design Wheels & Brakes****C1. Brake Assembly / Lining Cross-Reference**

This cross-reference identifies the proper brake lining for each of the brake assemblies listed. All linings require conditioning prior to use.

Abbreviations: pp = Pressure Plate tp = Torque Plate N/A = Not Available  
bp = Back Plate cp = Carrier Plate

Brake Assembly	Lining	Qty	Brake Assembly	Lining	Qty	Brake Assembly	Lining	Qty
35-200A	066-11100	2	30-45	066-11100	2	30-60A	066-10600	4
C2000	066-00504	2	30-51	066-10600	4	30-60B	066-10600	4
C7000	066-00504	2	30-51A	066-10600	4	30-61	066-10500	4
C7000A	066-00504	2	30-51B	066-10600	4	30-61A	066-03600	4
30-4	066-11100	2	30-52	066-10500	4	30-61B	066-03600	4
30-5	N/A		30-52A	066-10500	4	30-61D	066-10500	4
30-6	066-11100	2	30-52B	066-10500	4	30-61E	066-10500	4
30-7	066-11100	2	30-52D	066-10500	4	30-61F	066-10500	4
37-200-2	066-10600	8	30-52E	066-10500	4	30-63	066-10500	2
30-9	066-10600	2	30-52F	066-10500	4	30-63A	066-10500	2
30-9A	066-10600	2	30-52G	066-10500	4	30-63B	066-10500	2
30-9C	066-10600	2	30-52H	066-10500	4	30-63D	066-10500	2
30-9D	066-10600	2	30-52K	066-10500	4	30-63E	066-10500	2
30-9E	066-10600	2	30-52L	066-10500	4	30-63F	066-10500	2
3000-250	066-10600	4	30-52M	066-10500	4	30-63J	066-10500	2
3000-500	066-10600	4	30-52N	066-10500	4	30-63K	066-10500	2
30-18	066-10600	2	30-52P	066-10500	4	30-63M	066-10500	2
30-19	066-10600	2	30-52Q	066-10500	4	30-63P	066-10500	2
30-19A	066-10600	2	30-52S	066-10500	4	30-63Q	066-10500	2
30-21	066-10600	4	30-52T	066-10500	4	30-63S	066-10500	2
30-23	066-06500 pp	2	30-52U	066-10500	4	30-65	066-10500	4
	066-06200 bp	2	30-52V	066-10500	4	30-65A	066-10500	4
30-23A	066-06500 pp	2	30-52W	066-10500	4	30-65E	066-10500	4
	066-06200 bp	2	30-52X	066-10500	4	30-66	066-04400	4
30-23B	066-06500 pp	2	30-52Y	066-10500	4	30-66A	066-11000	4
	066-06200 bp	2	30-52Z	066-10500	4	30-66B	066-11000	4
30-23C	066-06500 pp	2	30-52AA	066-10500	4	30-66C	066-02200	4
	066-06200 bp	2	30-52AB	066-10500	4	30-66D	066-02200	4
30-23D	066-06500 pp	2	30-52AC	066-10500	4	30-66F	066-04400	4
	066-06200 bp	2	30-53	066-11200	2	30-66G	066-09700	4
30-24	066-10600	4	30-53A	066-11200	2	30-66H	066-02200	4
30-28B	066-03300	6	30-54	066-10500	4	30-67	066-10800	4
30-28C	066-03300	6	30-54A	066-10500	4	30-67A	066-10800	4
30-28D	066-03300	6	30-54B	066-10500	4	30-67B	066-10800	4
30-30	066-10500	2	30-54C	066-10500	4	30-67C	066-10800	4
30-31	066-11700 tp	4	30-55	066-10500	2	30-67D	066-10800	4
	066-11900 cp	4	30-55B	066-10500	2	30-67E	066-10800	8
	066-11800 bp	4	30-56	066-10500	2	30-67X	066-10800	4
30-32	N/A		30-56A	066-10500	2	30-68	066-03300	6
30-32A	066-10600	4	30-56B	066-10500	2	30-68A	066-03300	6
30-32B	066-10600	4	30-56C	066-10500	2	30-68B	066-03300	6
30-32C	066-10600	4	30-56D	066-10500	2	30-69A	066-02200	4
30-32D	066-10600	4	30-56F	066-10500	2	30-69B	066-02200	4
30-32E	066-10600	4	30-58A	N/A			066-06500 pp	4
30-35	066-10600	4	30-58B	N/A			066-06200 bp	4
30-40	066-10600	2	30-59	066-11200	2	30-74B	066-06700	4
30-40A	066-10600	2	30-59A	066-11200	2	30-75	066-10500	2
30-41	066-10600	4	30-59D	066-11200	2	30-75A	066-10500	2
30-41A	066-10600	4	30-59E	066-11200	2	30-75B	066-10500	2
30-41B	066-10600	4	30-60	066-10600	4	30-75X	066-10500	2

## C1. Brake Assembly / Lining Cross-Reference (Cont'd)

Brake Assembly	Lining	Qty	Brake Assembly	Lining	Qty	Brake Assembly	Lining	Qty
30-79	066-10500	2	30-144	066-09000	8	30-308	066-14800	4
30-79A	066-10500	2	30-144A	066-09000	8	30-312	066-09100 pp	1
30-79B	066-10500	2	30-144B	066-09000	8		066-09200 bp	1
30-83	066-06200	4	30-145	066-09700	6	C-30018	066-30026	2
30-83A	066-06200	4		066-09100 pp	2	C-30018-1	066-30026	2
30-84	066-10800	8	30-146	066-09200 bp	2	C-30018-2	066-30026	2
30-88	066-02200	8		066-09100 pp	2	C-30018-3	066-30026	2
30-89	066-10800	6	30-146A	066-09200 bp	2	C-30018-4	066-30026	2
30-89A	066-10800	6	30-148	066-11300	16	C-30018-5	066-30026	2
30-89B	066-10800	6	30-149	066-06600	12	C-30018-6	066-30026	2
30-89C	066-10800	6	30-158	066-06800	8	C-30018-7	066-30026	2
30-89E	066-10800	6	30-159	066-09000	8	D-30118-3	066-30026	4
30-91	066-11300	12	30-159A	066-09000	8	D-30118-4	066-30026	4
30-93	066-04400	6	30-159B	066-09000	8	D-30118-5	066-30026	4
30-93A	066-02200	6	30-159C	066-09000	8	D-30118-6	066-30026	4
30-93B	066-04400	6	30-163	066-15300	8	D-30118-7	066-30026	4
30-93C	066-09700	6	30-163 RH	066-15300	8	D-30118-8	066-30026	4
30-93D	066-04400	6	30-164	066-06200	2	D-30118-9	066-30026	4
30-93E	066-04400	6	30-170	066-10000	8	D-30118-10	066-30026	4
30-94	066-10800	8	30-176	066-10800	4	C-30764-5	066-30026	2
30-95	066-03300	8	30-181A	066-10600	2	C-30764-6	066-30026	2
30-95A	066-06600	8	30-182	066-15300	8	C-30764-7	066-30026	2
30-95B	066-06600	8	30-182A	066-15300	8	D-30793-3	066-30026	4
30-96	066-06200	8	30-184	066-10800	8	D-30793-4	066-30026	4
30-97	066-06400	8	30-195	066-10800	4	D-30793-5	066-30026	4
30-98	066-10800	12	30-195A	066-10800	4	D-30793-6	066-30026	4
30-98A	066-10800	12	30-208	N/A				
30-98B	066-10800	12	30-208A	066-12901	2			
30-98C	066-10800	12	30-210	066-13100	16			
30-98D	066-10800	12	30-210A	066-13100	16			
30-99	066-06600	8	30-210C	066-13100	16			
30-99A	066-06600	8	30-214	066-10500	2			
30-100	066-06600	8	30-214B	066-10500	2			
30-103	066-11300	16		066-13500 pp	2			
30-106	066-06800	16		066-13700 bp	2			
30-107	066-09000	8	30-224	066-10500	2			
30-107A	066-09000	8	30-231	066-06600	12			
30-107B	066-09000	8	30-233	066-06200	4			
30-107C	066-09000	8	30-233A	066-06200	4			
30-107D	066-09000	8	30-233B	066-06200	4			
30-107E	066-09000	8	30-233C	066-15100	4			
30-111	066-10800	8	30-233E	066-15500	4			
30-113	066-06400	8	30-233E RH	066-15500	4			
30-113A	066-06400	8	30-236	066-10500	2			
30-123	066-06800	12	30-239	066-14100	2			
30-127	066-06200	4	30-239A	066-14100	2			
30-127A	066-06200	4	30-239B	066-14100	2			
30-127C	066-06200	4	30-241	066-10500	4			
30-127D	066-06200	4	30-269	066-04400	4			
30-129	066-06200	4	30-280	066-10800	4			
30-131	066-09000	8		066-09100 pp	1			
30-133	066-10500	2	30-290	066-09200 bp	1			
30-138	066-06800	6		066-09100 pp	1			
30-139	066-06200	8	30-293	066-09200 bp	1			
30-141	066-07300	8		066-09100 pp	1			
30-142	066-07300	8	30-293 RH	066-09200 bp	1			
30-143	066-07300	8						



**NEW!**

PERFORMANCE THAT GOES THE DISTANCE

*Aircraft brake discs engineered for longer life*



- 70% longer wear life vs. standard discs
- 25% longer life vs. competitors
- Up to 50% increase in lining life operational impact

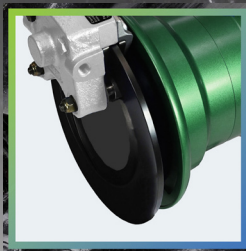
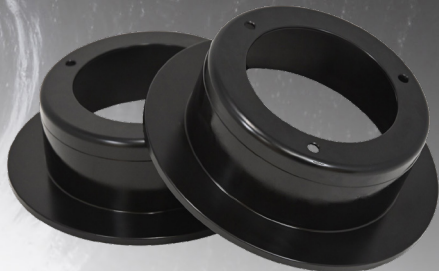

Cleveland Wheel & Brake Systems  
1160 Center Road  
Avon, Ohio 44011

Technical Services:  
[clevelandwheelandbrake.com/contact](http://clevelandwheelandbrake.com/contact)  
1-800-BRAKING (1-800-272-5464)

