

Technician's Service Guide



CLEVELAND
WHEEL & BRAKE SYSTEMS

AWBTSG0001-29

Reference

Publication Number: **AWBTSG0001-29/USA**
AWBTSG0001 Issue 29, Dated: **March 24, 2026**

IMPORTANT NOTE

Use of other manufacturer's components with original Cleveland Wheel & Brake Systems (CWBS) assemblies will void the CWBS warranty.

SAFETY WARNING



FAILURE OR IMPROPER SELECTION OR IMPROPER USE OF THE PRODUCTS AND/OR SYSTEMS DESCRIBED HEREIN OR RELATED ITEMS CAN CAUSE DEATH, PERSONAL INJURY AND PROPERTY DAMAGE.

This document and other information from Cleveland Wheel & Brake Systems (CWBS) and authorized distributors provide product and/or system options for further investigation by users having technical expertise. It is important that you analyze all aspects of your application, including consequences of any failure, and review the information concerning the product or system at clevelandwheelandbrake.com using the Products category pages or Find by Aircraft function. Due to the variety of operating conditions and applications for these products or systems, the user, through its own analysis and testing, is solely responsible for making the final selection of the products and systems and assuring that all performance, safety and warning requirements of the application are met.

The products described herein, including without limitation, product features, specifications, designs, availability and pricing, are subject to change by CWBS at any time without notice.

CONTACT INFORMATION

Cleveland Wheel & Brake Systems, 1160 Center Road • Avon, Ohio 44011

www.clevelandwheelandbrake.com

E-mail: clevelandwbhelp@clevelandwbs.com

Customer Support Fax: 440-937-5409

Technical Service Hotline: 1-800-BRAKING (1-800-272-5464)

Literature Requests: www.veryon.com

Reference

USAGE

The procedures in this technician's guide are applicable to external design wheels and brakes and auxilliary wheels only. Many wheel and brake assemblies have a manual expressly written for their overhaul and maintenance type activities. Before using this guide, consult the Cleveland Wheel & Brake Systems (CWBS) Technical Support Team for availability of those manuals.

This guide is intended as a condensed version of specific data found in AWBCMM0001, the generic Component Maintenance Manual (external design wheels & brakes). AWBCMM0001 contains detailed maintenance/overhaul procedures for external design wheels & brakes that do not have a manual. In addition to this guide and AWBCMM0001, refer to resources found at clevelandwheelandbrake.com where you can find illustrated parts breakdown. These documents are intended to supplement, not replace, the airframe manufacturer's instructions when CWBS products are used. Consult the Aircraft Maintenance Manual and Airframe Log Books (for optional installations) to confirm the approved part numbers for the particular aircraft application. If any inconsistencies are observed in this data, please notify CWBS Customer Support.

UPDATES

The technician's guide publication number will reflect the latest issue in effect with a suffix "-X" (X being the latest issue), e.g. AWBTSG0001-29. The publication number will advance numerically with each update issued. Each page will reflect the latest issue in effect. Refer to the **Revisions Highlights Page** in this publication for details of each update.

Consult the CWBS website for current service publications, www.clevelandwheelandbrake.com or contact CWBS Technical Support at 1-800-BRAKING (1-800-272-5464).

Revision Highlights

Revision 29, dated March 24, 2026

Page	Description of Change
Front Cover	Updated artwork
Back Cover	Updated artwork
6	Added the following brake discs to the min thickness table 564-02000, 564-21600, 564-22201 564-22202
9	E. Brake Lining Cross-Reference updated 30-163: Lining 066-15300 30-163 RH: Lining 066-15300 30-182: Lining 066-15300
23	M. Primers and Paints updated MIL-PRF-26915A removed P/N 11011-10014

Table of Contents

SECTION	PAGE
A. Conditioning Procedures.....	2
B. Brake Lining Wear Limits	3
C. Brake Disc Minimum Thickness.....	4
D. Chrome Disc Maintenance.....	7
E. Brake Lining Cross-Reference.....	7
F. Wheel Assembly Torque Values	11
G. Tire Inflation Valve Stem Torque	16
H. Back Plate Tie Bolt Torque.....	17
I. Special Tools	21
J. Elastomeric Compound Lubricants.....	21
K. Lubricants.....	21
L. Repair Materials	22
M. Primers and Paints	23
N. Chemical Stripping Agents.....	23

A. Conditioning Procedures

When new linings have been installed, it is important to condition them properly to obtain the service life designed into them. The metallic and organic linings have different operating characteristics. Separate conditioning procedures are given for metallic and organic linings.

ORGANIC LININGS	METALLIC LININGS
<ol style="list-style-type: none"> 1. Taxi aircraft for 1500 feet with engine at 1700 rpm applying brake pedal force as needed to develop a 5-10 mph taxi speed. 2. Allow the brakes to cool for 10 to 15 minutes. 3. Apply brakes and check for restraint at high static throttle. If brakes hold, conditioning is complete. 4. If brakes cannot hold aircraft during static run-up, allow brakes to completely cool and repeat steps 1 through 3. 	<ol style="list-style-type: none"> 1. Perform two (2) consecutive full stop braking applications from 30 to 35 knots. Do not allow the brake discs to cool substantially between the stops. 2. Allow the brakes to cool for 10 to 15 minutes. 3. Apply brakes and check for restraint at high static throttle. If brakes hold, conditioning is complete. 4. If brakes cannot hold aircraft during static run-up, allow brakes to cool completely and repeat steps 1 through 3.

CAUTION: DUE TO THE EFFICIENCY OF THESE BRAKES, EXTREMELY HARD BRAKING ON AIRCRAFT WITH TAIL WHEELS COULD RESULT IN LIFTING THE TAIL FROM THE GROUND.

These conditioning procedures will wear off high spots and generate sufficient heat to create a thin layer of glazed material at the lining friction surface. **Normal brake usage should generate enough heat to maintain the glaze throughout the life of the lining.**

Properly conditioned linings will provide many hours of maintenance free service. A visual inspection of the brake disc will indicate the lining condition. A smooth surface, one without grooves, indicates the linings are properly glazed. If the disc is rough (grooved), the linings must be reglazed. The conditioning procedure should be performed whenever the rough disc condition is observed. Light use, such as in taxiing, will cause the glaze to be worn rapidly and reduce the designed service life of the linings and discs.

B. Brake Lining Wear Limits

The minimum replacement thickness on metallic and organic linings is 0.100 inch (2.54 mm) except as noted below. Refer to Figure A1.

NOTE: On some designs the metallic lining is bonded directly to the pressure plate and back plate. In these cases, the part should be replaced when the lining material is worn to 0.030 inch (0.76 mm) thick.

For equipment used on Piper Aztec (using either 164-00206 or 164-03206 disc), see PRM19 or follow the procedure below:

- First, measure linings as shown in Figure A1. Linings worn below .100 inch are cause for replacement.
- If linings are still usable or are replaced, measure the cumulative thickness of two linings, disc and pressure plate as shown in Figure A1-1. If the stack measures less than 1.00 (1 inch) with good linings (linings above .100 inch) the brake disc is considered below minimum wear thickness and should be replaced.

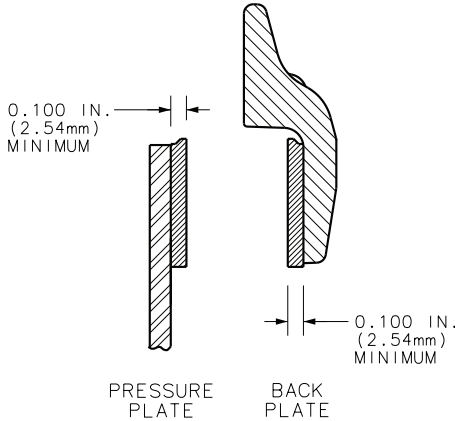

Figure A1
Minimum Lining Thickness

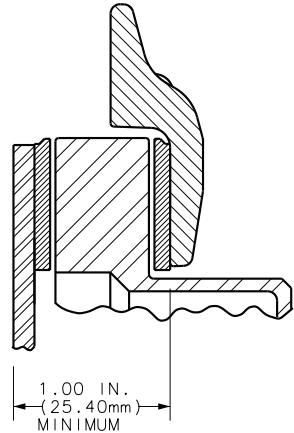

Figure A1-1
Disc Wear Measurement
(Piper Aztec)

C. Brake Disc Minimum Thickness



Figure A2 – Disc Thickness Measurement

Under average field conditions, a brake disc should give years of trouble free service. However, unimproved fields, standing water, heavy industrial pollution or infrequent use of the aircraft may necessitate more frequent inspection of discs to prolong the life of the brake lining.

Generally, the disc faces should be checked for wear (Figure A2 Dim. “A”), grooves, deep scratches, excessive general pitting or coning of the brake disc. Coning beyond 0.015 inch (0.381 mm) in either direction would be cause for replacement.

Single or isolated grooves up to 0.030 inch (0.76 mm) deep should not be cause for replacement, although general grooving of the disc faces will reduce lining life.

Discs are plated for special applications only; therefore, rust in varying degrees can occur. If a powder rust appears, one or two braking applications during taxi should wipe the disc clear. Rust allowed to progress beyond this point may require removal of the disc from wheel assembly to properly clean both faces. Wire brushing followed by sanding with 220 grit sandpaper can restore the braking surface for continued use.

Note: 164-1XXXX part numbers designate chrome plated discs.

464-XXXXX part numbers designate performance gold discs which are no longer manufactured.

564-XXXXX part numbers designate Obsidian discs.

C. Brake Disc Minimum Thickness

Part Number	"A" in/mm
159-00104	0.225/5.715
159-00204	0.475/12.065
164-00206	See Page 3
164-00300	0.205/5.207
164-00400	0.162/4.115
164-00500	0.157/3.988
164-00700	0.345/8.763
164-00806	0.334/8.484
164-00900	0.227/5.766
164-01000	0.345/8.763
164-01100	0.345/8.763
164-01300	0.227/5.764
164-01406	0.334/8.484
164-01501	0.327/8.306
164-01506	0.327/8.306
164-01600	0.157/3.988
164-01700	0.167/4.242
164-01900	0.227/5.766
164-02000	0.205/5.207
164-02201	0.345/8.763
164-02300	0.345/8.763
164-02501	0.445/11.303
164-02502	0.445/11.303
164-02503	0.445/11.303
164-02504	0.445/11.303
164-02505	0.445/11.303
164-02601	0.205/5.207
164-02700	0.330/8.382
164-02701	0.340/8.636
164-02706	0.330/8.382
164-02707	0.330/8.382
164-02800	0.227/5.766
164-02900	0.580/14.732
164-03006	0.282/7.163
164-03106	0.163/4.140
164-03206	See Page 3
164-03300	0.235/5.969
164-03506	0.260/6.604
164-03600	0.327/8.306
164-03601	0.327/8.306
164-03700	0.345/8.763
164-03906	0.600/15.240
164-04000	0.205/5.207

Part Number	"A" in/mm
164-04300	0.205/5.207
164-04406	0.334/8.484
164-04600	0.405/10.287
164-04700	0.345/8.763
164-04800	0.327/8.306
164-05006	0.475/12.065
164-05500	0.492/12.497
164-05606	0.395/10.033
164-05700	0.525/13.335
164-05806	0.395/10.033
164-06106	0.475/12.065
164-06306	0.465/11.81
164-06406	0.465/11.811
164-06506	0.240/6.096
164-06700	0.220/5.588
164-06900	0.205/5.207
164-07200	0.492/12.497
164-07306	0.395/10.033
164-07400	0.492/12.497
164-07500	0.205/5.207
164-07700	0.470/11.938
164-07800	0.450/11.43
164-07906	0.465/11.811
164-08100	0.450/11.43
164-08200	0.327/8.306
164-08300	0.327/8.306
164-08406	0.330/8.382
164-08500	0.325/8.255
164-08800	0.190/4.826
164-08900	0.330/8.382
164-09000	0.330/8.382
164-09100	0.492/12.497
164-09200	0.190/4.826
164-09300	0.190/4.826
164-09400	0.190/4.826
164-09500	0.325/8.255
164-09600	0.325/8.255
164-09700	0.325/8.255
164-09900	0.275/6.985
164-10500	0.157/3.988
164-10700	0.345/8.763
164-10900	0.227/5.766
164-11501	0.327/8.306

Part Number	"A" in/mm
164-11700	0.164/4.166
164-11800	0.162/4.115
164-11900	0.227/5.766
164-12000	0.205/5.207
164-12300	0.345/8.763
164-12501	0.445/11.303
164-12502	0.445/11.303
164-12504	0.445/11.303
164-12505	0.445/11.303
164-12601	0.205/5.207
164-13300	0.235/5.969
164-13600	0.327/8.306
164-13601	0.327/8.306
164-14000	0.205/5.207
164-14300	0.205/5.207
164-14800	0.327/8.306
164-16700	0.220/5.588
164-17500	0.205/5.207
164-18300	0.327/8.306
164-18800	0.190/4.826
164-18900	0.330/8.382
164-19000	0.330/8.382
164-19200	0.191/4.826
164-19300	0.190/4.826
164-19400	0.190/4.826
164-19500	0.325/8.255
164-19600	0.325/8.255
164-19700	0.325/8.255
164-20100	0.250/6.350
164-20206	0.334/8.484
164-20306	0.465/11.811
164-20500	0.525/13.335
164-20600	0.455/11.557
164-20700	0.410/10.414
164-20806	0.475/12.065
164-20900	0.410/10.414
164-21000	0.436/11.074
164-21100	0.492/12.497
164-21200	0.327/8.306
164-21406	0.334/8.484
164-21600	0.405/10.287
164-21700	0.475/12.065
164-21900	0.590/14.986

C. Brake Disc Minimum Thickness

Part Number	"A" in/mm
164-22000	0.360/9.144
164-22201	0.537/13.640
164-22202	0.537/13.640
164-22400	0.385/9.779
164-22900	0.410/10.414
164-23000	0.565/14.351
164-23001	0.582/14.783
164-23002	0.582/14.783
164-23100	0.345/8.763
164-23300	0.475/12.065
164-23400	0.205/5.207
164-23600	0.190/4.826
164-23900	0.325/8.255
164-24000	0.325/8.255
164-24100	0.325/8.255
164-24200	0.167/4.242
164-24400	0.290/7.366
164-24500	0.327/8.306
164-24501	0.327/8.306
164-24800	0.330/8.382
164-25200	0.312/7.925
164-25700	0.445/11.303
164-25800	0.459/11.659
164-30007	0.190/4.826
164-30195	0.190/4.826
164-30388	0.325/8.255
164-30398	0.325/8.255
164-30414	0.325/8.255
164-30440	0.190/4.826
164-30615-1	0.190/4.826
164-30615-2	0.330/8.382
164-30615-3	0.330/8.382
164-30804-1	0.190/4.826
164-30804-2	0.330/8.382
164-30804-3	0.330/8.382
464-11501	0.327/8.306
464-11700	0.164/4.166
464-12000	0.205/5.207
464-12601	0.205/5.207
464-13601	0.327/8.306
464-14000	0.205/5.207
464-14300	0.205/5.207
464-17500	0.205/5.207
464-18300	0.327/8.306
564-02000	0.205/5.207
564-04000	0.205/5.207
564-21600	0.405/10.287
564-22201	0.537/13.640
564-22202	0.537/13.640

D. Chrome Disc Maintenance

The primary purpose of chrome plated discs is to retard corrosion on the disc flange (rubbing surface) which, if pitted, will wear out linings rapidly. Chrome is a porous material which will allow moisture to penetrate and discolor, giving the appearance of corrosion. To restore the original luster of the cup surface, polish with common automotive chrome polish and a non-metallic abrasive pad (such as 3M Scotch Brite®) – DO NOT USE steel wool. The main area of concern should be the disc flange. As long as it is clean and corrosion-free, the disc will provide the service life designed into it.

The plating will increase the life of a standard disc. When the plating wears off, which it eventually will, you then have a standard disc to wear down to the minimum thickness. The added benefit is the plating will be intact on the non-rubbing surfaces as opposed to the paint on a standard disc.

E. Brake Lining Cross-Reference

This cross-reference identifies the proper brake lining for each of the brake assemblies listed. All linings require conditioning prior to use.

Abbreviations:

Pp = Pressure Plate
Bp = Back Plate

Tp = Torque Plate
Cp = Carrier Plate

N/A = Not Available

Brake Assembly	Lining	Qty
35-200A	066-11100	2
C2000	066-00504	2
C7000	066-00504	2
C7000A	066-00504	2
30-4	066-11100	2
30-5	N/A	
30-6	066-11100	2
30-7	066-11100	2
37-200-2	066-10600	8
30-9	066-10600	2
30-9A	066-10600	2
30-9C	066-10600	2
30-9D	066-10600	2
30-9E	066-10600	2
3000-250	066-10600	2
3000-500	066-10600	2
30-18	066-10600	2
30-19	066-10600	2
30-19A	066-10600	2
30-21	066-10600	4

Brake Assembly	Lining	Qty
30-23	066-06500 Pp	2
	066-06200 Bp	2
30-23A	066-06500 Pp	2
	066-06200 Bp	2
30-23B	066-06500 Pp	2
	066-06200 Bp	2
30-23C	066-06500 Pp	2
	066-06200 Bp	2
30-23D	066-06500 Pp	2
	066-06200 Bp	2
30-24	066-10600	4
30-28B	066-03300	6
30-28C	066-03300	6
30-28D	066-03300	6
30-30	066-10500	2
30-31	066-11700 Tp	4
	066-11900 Cp	4
	066-11800 Bp	4
30-32	N/A	
30-32A	066-10600	4

E. Brake Lining Cross-Reference

Brake Assembly	Lining	Qty
30-32B	066-10600	4
30-32C	066-10600	4
30-32D	066-10600	4
30-32E	066-10600	4
30-35	066-10600	4
30-40	066-10600	2
30-40A	066-10600	2
30-41	066-10600	4
30-41A	066-10600	4
30-41B	066-10600	4
30-45	066-11100	2
30-51	066-10600	4
30-51A	066-10600	4
30-51B	066-10600	4
30-52	066-10500	4
30-52A	066-10500	4
30-52B	066-10500	4
30-52D	066-10500	4
30-52E	066-10500	4
30-52F	066-10500	4
30-52G	066-10500	4
30-52H	066-10500	4
30-52K	066-10500	4
30-52L	066-10500	4
30-52M	066-10500	4
30-52N	066-10500	4
30-52P	066-10500	4
30-52Q	066-10500	4
30-52S	066-10500	4
30-52T	066-10500	4
30-52U	066-10500	4
30-52V	066-10500	4
30-52W	066-10500	4
30-52X	066-10500	4
30-52Y	066-10500	4
30-52Z	066-10500	4
30-52AA	066-10500	4
30-52AB	066-10500	4
30-52AC	066-10500	4
30-53	066-11200	2
30-53A	066-11200	2
30-54	066-10500	4
30-54A	066-10500	4
30-54B	066-10500	4
30-54C	066-10500	4
30-55	066-10500	2
30-55B	066-10500	2
30-56	066-10500	2

Brake Assembly	Lining	Qty
30-56A	066-10500	2
30-56B	066-10500	2
30-56C	066-10500	2
30-56D	066-10500	2
30-56F	066-10500	2
30-58A	N/A	
30-58B	N/A	
30-59	066-11200	2
30-59A	066-11200	2
30-59D	066-11200	2
30-59E	066-11200	2
30-60	066-10600	4
30-60A	066-10600	4
30-60B	066-10600	4
30-61	066-10500	4
30-61A	066-03600	4
30-61B	066-03600	4
30-61D	066-10500	4
30-61E	066-10500	4
30-61F	066-10500	4
30-63	066-10500	2
30-63A	066-10500	2
30-63B	066-10500	2
30-63D	066-10500	2
30-63E	066-10500	2
30-63F	066-10500	2
30-63J	066-10500	2
30-63K	066-10500	2
30-63M	066-10500	2
30-63P	066-10500	2
30-63Q	066-10500	2
30-63S	066-10500	2
30-65	066-10500	4
30-65A	066-10500	4
30-65E	066-10500	4
30-66	066-04400	4
30-66A	066-11000	4
30-66B	066-11000	4
30-66C	066-02200	4
30-66D	066-02200	4
30-66F	066-04400	4
30-66G	066-09700	4
30-66H	066-02200	4
30-67	066-10800	4
30-67A	066-10800	4
30-67B	066-10800	4
30-67C	066-10800	4
30-67D	066-10800	4

E. Brake Lining Cross-Reference

Brake Assembly	Lining	Qty
30-67E	066-10800	8
30-67X	066-10800	4
30-68	066-03300	6
30-68A	066-03300	6
30-68B	066-03300	6
30-69A	066-02200	4
30-69B	066-02200	4
37-200A	066-06500 Pp	4
	066-06200 Bp	4
30-74B	066-06700	4
30-75	066-10500	2
30-75A	066-10500	2
30-75B	066-10500	2
30-75X	066-10500	2
30-79	066-10500	2
30-79A	066-10500	2
30-79B	066-10500	2
30-83	066-06200	4
30-83A	066-06200	4
30-84	066-10800	8
30-88	066-02200	8
30-89	066-10800	6
30-89A	066-10800	6
30-89B	066-10800	6
30-89C	066-10800	6
30-89E	066-10800	6
30-91	066-11300	12
30-93	066-04400	6
30-93A	066-02200	6
30-93B	066-04400	6
30-93C	066-09700	6
30-93D	066-04400	6
30-93E	066-04400	6
30-94	066-10800	8
30-95	066-03300	8
30-95A	066-06600	8
30-95B	066-06600	8
30-96	066-06200	8
30-97	066-06400	8
30-98	066-10800	12
30-98A	066-10800	12
30-98B	066-10800	12
30-98C	066-10800	12
30-98D	066-10800	12
30-99	066-06600	8
30-99A	066-06600	8
30-100	066-06600	8
30-103	066-11300	16
30-106	066-06800	16
30-107	066-09000	8

Brake Assembly	Lining	Qty
30-107A	066-09000	8
30-107B	066-09000	8
30-107C	066-09000	8
30-107D	066-09000	8
30-107E	066-09000	8
30-111	066-10800	8
30-113	066-06400	8
30-113A	066-06400	8
30-123	066-06800	12
30-127	066-06200	4
30-127A	066-06200	4
30-127C	066-06200	4
30-127D	066-06200	4
30-129	066-06200	4
30-131	066-09000	8
30-133	066-10500	2
30-138	066-06800	6
30-139	066-06200	8
30-141	066-07300	8
30-142	066-07300	8
30-143	066-07300	8
30-144	066-09000	8
30-144A	066-09000	8
30-144B	066-09000	8
30-145	066-09700	6
30-146	066-09100 Pp	2
	066-09200 Bp	2
30-146A	066-09100 Pp	2
	066-09200 Bp	2
	066-09200 Bp	2
30-148	066-11300	16
30-149	066-06600	12
30-158	066-06800	8
30-159	066-09000	8
30-159A	066-09000	8
30-159B	066-09000	8
30-159C	066-09000	8
30-163	066-15300	8
30-163 RH	066-15300	8
30-164	066-06200	2
30-170	066-10000	8
30-176	066-10800	4
30-181A	066-10600	2
30-182	066-15300	8
30-182A	066-15300	8
30-184	066-10800	8
30-195	066-10800	4
30-195A	066-10800	4
30-208	N/A	
30-208A	066-12901	2

E. Brake Lining Cross-Reference

Brake Assembly	Lining	Qty
30-210	066-13100	16
30-210A	066-13100	16
30-210C	066-13100	16
30-214	066-10500	2
30-214B	066-10500	2
30-220	066-13500 Pp	2
	066-13700 Bp	2
30-224	066-10500	2
30-231	066-06600	12
30-233	066-06200	4
30-233A	066-06200	4
30-233B	066-06200	4
30-233C	066-15100	4
30-233E	066-15500	4
30-233E RH	066-15500	4
30-236	066-10500	2
30-239	066-14100	2
30-239A	066-14100	2
30-239B	066-14100	2
30-241	066-10500	4
30-269	066-04400	4
30-280	066-10800	4
30-290	066-09100 Pp	1
	066-09200 Bp	1
30-293	066-09100 Pp	1
	066-09200 Bp	1
30-293 RH	066-09100 Pp	1
	066-09200 Bp	1
30-308	066-14800	2
30-312	066-09100 Pp	1
	066-09200 Bp	1
C-30018	066-30026	2
C-30018-1	066-30026	2
C-30018-2	066-30026	2
C-30018-3	066-30026	2
C-30018-4	066-30026	2
C-30018-5	066-30026	2
C-30018-6	066-30026	2
C-30018-7	066-30026	2
D-30118-3	066-30026	4
D-30118-4	066-30026	4
D-30118-5	066-30026	4
D-30118-6	066-30026	4
D-30118-7	066-30026	4
D-30118-8	066-30026	4
D-30118-9	066-30026	4
D-30118-10	066-30026	4
C-30764-5	066-30026	2
C-30764-6	066-30026	2
C-30764-7	066-30026	2
D-30793-3	066-30026	4
D-30793-4	066-30026	4
D-30793-5	066-30026	4
D-30793-6	066-30026	4

F. Wheel Assembly Torque Values

Torque Values

CAUTION: DO NOT LUBRICATE ANY HARDWARE THAT IS SPECIFIED AS A “DRY” TORQUE VALUE. IF THERE IS A CONFLICT OR QUESTION REGARDING TORQUE METHODS OR VALUES ON YOUR ASSEMBLY, PLEASE CONTACT CWBS CUSTOMER SUPPORT FOR RESOLUTION.

All wheel assembly tie bolt and nut torque values listed are to be applied to the nut only. A “D” shown adjacent to the torque value indicates the value to be a “Dry” torque only. An “L” shown adjacent to the torque value indicates a “Lube” torque only. Lube requires the application of a thread lubricant to all friction surfaces of the hardware prior to torquing. Only use the thread lubricant specified for your wheel assembly.

[A5-#] = Code for inflation valve stem torque. See appropriate dash number, -#, in Table G for torque value.

Bearing Grease

CAUTION: DO NOT MIX AVIATION WHEEL BEARING GREASES WITH EACH OTHER. IF USING OTHER APPROVED GREASE, COMPLETE REMOVAL OF CONTAINED GREASE AND BEARING CLEANING IS REQUIRED. REPLACEMENT OF PREVIOUSLY LUBRICATED FELT SEALS IS ALSO REQUIRED.

Included in this section is wheel bearing grease information. Beginning March, 2007 all active wheel assemblies listed in the torque values table, except those noted for amphibious application, will be shipped from the CWBS facility with the bearings packed with Mobil Aviation Grease SHC 100, the approved preferred grease for all Cleveland Wheel & Brake Systems wheel assemblies. If your non-amphibious wheel assembly was shipped prior to March 2007 it may contain other approved bearing grease. To change to the Mobil Aviation Grease SHC 100, you must completely remove the contained grease and clean the bearings. You must also replace any felt grease seals which were previously lubricated with other approved grease.

Refer to CWBS Component Maintenance Manual, AWBCMM0001, latest issue for additional information and grease packing instructions.

F. Wheel Assembly Torque Values

Table Flag Note Legend:

Material Column Designations:

“**A**” Aluminum “**M**” Magnesium

(1) For assistance contact the Technical Services Hotline (page i).

Thread Lubricant:

(2) Use SAE AMS2518 (ref MIL-T-5544).

(3) Use MIL-PRF-83483 (Molydisulphide).

Wheel Bearing Grease:

All active wheel assemblies listed are shipped with Mobil Aviation Grease SHC 100 except:

(4) Wheel uses BG Products HCF Grease P/N 605 (Amphibious)

(8) Wheel uses OMNI Waterproof Green Grease, No. 2 (Amphibious).

(9) Wheel uses Mobil Aviation Grease SHC 100 ONLY.

Torque Values:

(5) Dry torque brake disc bolts to 80 in-lbs.

(6) Dry torque brake disc bolts to 150 in-lbs.

(7) Torque value is dependent on hardware configuration. PRM's are in development to release the hardware upgrade for the following assemblies. In the interim, follow the wheel assembly nameplate for torque value. The table below is for reference only. For assistance contact the Technical Services Hotline (Page i).

Wheel Assembly	Nut / Washer	Torque in-lb (N-M)
40-87C, 40-110, 40-168	094-01200 / 095-10400	75 D (8.5)
	094-10300 / 095-10200	90 D (10.2)
40-87	094-01200 / 095-10400 qty-6	75 D (8.5)
	094-10300 / 095-10400 qty-3	90 D (10.2)
40-151, 40-151A, 40-230	094-01200 / 095-10200	75 D (8.5)
	094-10300 / 095-10200	90 D (10.2)
40-87A, 40-87D, 40-87F, 40-110B, 40-152	094-01200 / 095-10400	75 D (8.5)
	094-10300 / 095-10400	90 D (10.2)

F. Wheel Assembly Torque Values

Wheel Assembly	Bolt Torque		Wheel Matl
	in-lb	N•m	
27-100D	90 D	10.2	A
21-100D	90 D	10.2	M
3080A	90 D	10.2	M
3080B	90 D	10.2	M
3070	90 D	10.2	M
3040	90 D	10.2	A
3050	90 D	10.2	A
3050A	90 D	10.2	A
38501	90 D	10.2	M
40-12	90 D	10.2	M
40-12A	90 D	10.2	M
40-18	90 D	10.2	M
40-19	90 D	10.2	A
40-19A	90 D	10.2	A
40-21	90 D	10.2	A
40-24	90 D	10.2	A
40-28	90 D	10.2	M
40-28D	90 D	10.2	M
40-30A	90 D	10.2	A
40-32	90 D	10.2	A
40-34	90 D	10.2	M
40-37	90 D	10.2	A
40-40A	135-145 D	15.3-16.4	M
40-40B	135-145 D	15.3-16.4	M
40-40C	90 D	10.2	M
40-40D	150 D	16.9	M
40-41	150 D	16.9	M
40-46	90 D	10.2	A
40-47	150 D	16.9	A
40-50	90 D	10.2	A
40-55	90 D	10.2	A
40-56	150 D	16.9	M
40-56B	150 D	16.9	M
40-56C	150 D	16.9	M
40-57	90 D	10.2	A
40-57A	90 D	10.2	A
40-58	90 D	10.2	M
40-59	150 D	16.9	M
40-59A	150 D	16.9	M
40-59B	150 D	16.9	M
40-59D	150 D	16.9	M
40-59E	150 D	16.9	M
40-60	90 D	10.2	M
40-60A	90 D	10.2	A
40-61	90 D	10.2	M
40-66	90 D	10.2	A
40-67	90 D	10.2	A
40-74	90 D	10.2	A
40-74A	90 D	10.2	A
40-74B	90 D	10.2	A
40-75B	150 D	16.9	M
40-75D	150 D	16.9	M
40-75E	150 D	16.9	M
40-75F	150 D	16.9	M

Wheel Assembly	Bolt Torque		Wheel Matl
	in-lb	N•m	
40-75G	150 D	16.9	M
40-75H	150 D	16.9	M
40-75J	150 D	16.9	M
40-75P	150 D	16.9	M
40-75S	150 D	16.9	M
40-75T	150 D	16.9	M
40-75W	150 D	16.9	M
40-75Z	150 D	16.9	M
40-75AA	150 D	16.9	M
40-76A	150 D	16.9	M
40-76B	150 D	16.9	M
40-76C	150 D	16.9	M
40-76D	150 D	16.9	M
40-76E	150 D	16.9	M
40-76F	150 D	16.9	M
40-76G	150 D	16.9	M
40-76H	150 D	16.9	M
40-76P	150 D	16.9	M
40-76-1	150 D	16.9	(1)
40-77	Refer to PRM86		M
40-77A	Refer to PRM94		M
40-77B	Refer to PRM94		M
40-77C	Refer to PRM83		M
40-77D	90 D	10.2	M
40-77E	Refer to PRM83		M
40-77F	Refer to PRM94		M
40-77G	90 L (2)	10.2	M
40-77H	90-100 L (2)	10.2-11.3	M
40-78	Refer to PRM96		M
40-78A	Refer to PRM96		A
40-78B	Refer to PRM96		M
40-78E	Refer to PRM96		M
40-78J	Refer to PRM96		A
40-79	150 D	16.9	M
40-83	150 D	16.9	M
40-83A	150 D	16.9	M
40-83B	150 D	16.9	M
40-84	150 D	16.9	M
40-84A	150 D	16.9	M
40-84B	150 D	16.9	M
40-86	150 D	16.9	M
40-86A	150 D	16.9	M
40-86B	150 D	16.9	M
40-86E	150 D	16.9	M
40-86F	150 D	16.9	M
40-87	(7)		M
40-87A	(7)		M
40-87C	(7)		A
40-87D	(7)		M
40-87F	(7)		M
40-87G	115-135 D	13.0-15.3	M
40-87H	75 D	8.5	A
40-87J (8)	75 D	8.5	A
40-87K (4)	75 D	8.5	A

F. Wheel Assembly Torque Values

Wheel Assembly	Bolt Torque		Wheel Matl
	in-lb	N·m	
40-88C	150 D	16.9	M
40-90	150 D	16.9	M
40-90A	150 D	16.9	M
40-90B	150 D	16.9	M
40-90D	150 D	16.9	M
40-90E	150 D	16.9	M
40-90F	150 D	16.9	M
40-96E	150 D	16.9	M
40-97A	150 D	16.9	M
40-97B	150 D	16.9	M
40-97C	150 D	16.9	M
40-97D	150 D	16.9	M
40-97E	150 D	16.9	M
40-97F	150 D	16.9	M
40-98	150 D	16.9	M
40-98A	150 D	16.9	M
40-98D	150 D	16.9	M
40-98E	150 D	16.9	M
40-98F	150 D	16.9	M
40-98G	150 D	16.9	M
40-98H	150 D	16.9	M
40-98N	150 D	16.9	M
40-98P	150 D	16.9	M
40-99	90 D	10.2	M
40-101	90 D	10.2	A
40-101A	90 D	10.2	A
40-101D	90 D	10.2	A
40-101E	90 D	10.2	A
40-101F (8)	90 D	10.2	A
40-101G (4)	90 D	10.2	A
40-102	90 D	10.2	M
40-102A	90 D	10.2	M
40-103	90 D	10.2	A
40-103A	90 D	10.2	A
40-106	150 D	16.9	M
40-106A	150 D	16.9	M
40-107A [A5-3]	300 L (2)	33.9	M
40-110	(7)		M
40-110B	(7)		M
40-111	150 D	16.9	M
40-111A	150 D	16.9	M
40-112	90 D	10.2	A
40-113	90 D	10.2	A
40-113A	90 D	10.2	A
40-113B	90 D	10.2	A
40-113C	90 D	10.2	A
40-113X	90 D	10.2	A
40-115	90 D	10.2	M
40-115A	115-135 D	13.0-15.3	M
40-115B	115-135 D	13.0-15.3	M
40-115C	115-135 D	13.0-15.3	M
3080D (5)	90 D	10.2	M
40-117A	150 D	16.9	M
40-120	150 D	16.9	M

Wheel Assembly	Bolt Torque		Wheel Matl
	in-lb	N·m	
40-120A	150 D	16.9	M
40-120C	150 D	16.9	M
40-124	180 D	20.3	M
40-127	300 L (2)	33.9	A
40-128	180 D	20.3	M
40-128A	180 D	20.3	M
40-128C	180 D	20.3	M
40-128D	180 D	20.3	M
40-128E	180 D	20.3	M
40-129	90 D	10.2	A
40-130	90 D	10.2	M
40-131 (5)	90 D	10.2	M
40-132 [A5-1]	150 D	16.9	M
40-133	150 D	16.9	A
40-134 [A5-2]	150 D	16.9	M
40-134A [A5-2]	150 D	16.9	M
40-135	135-145 D	15.3-16.4	M
40-135A	150 D	16.9	M
40-135B	150 D	16.9	M
40-137	180 D	20.3	A
40-138A	150 D	16.9	M
40-138B	150 D	16.9	M
40-138C	180 D	20.3	M
40-139	150 D	16.9	A
40-140	150 D	16.9	M
40-140A	150 D	16.9	M
40-140B	150 D	16.9	M
40-140C	150 D	16.9	M
40-141	150 D	16.9	M
40-142	150 D	16.9	M
40-142A	150 D	16.9	M
40-143	150 D	16.9	M
40-148 [A5-3]	300 D	33.9	M
40-151	(7)		M
40-151A	(7)		A
40-152	(7)		M
40-162	150 D	16.9	M
40-163	150 D	16.9	M
40-166 [A5-1] (6)	300 D	33.9	M
40-167 (6)	300 D	33.9	M
40-168	(7)		A
40-169 [A5-1] (6)	150 D	16.9	M
40-170 [A5-3]	300 L (2)	33.9	M
40-170A [A5-3]	300 L (2)	33.9	A
40-170B [A5-3]	300 L (2)	33.9	M
40-171	180 D	20.3	M
40-172	180 D	20.3	M
40-174	300 L (2)	33.9	A
40-175	150 D	16.9	A
40-176 [A5-1]	300 D	33.9	A
40-176A [A5-1]	300 D	33.9	A
40-177A (9)	150 D	16.9	M
40-179 (9)	150 D	16.9	A
40-179A	150 D	16.9	A

F. Wheel Assembly Torque Values

Wheel Assembly	Bolt Torque		Wheel Matl
	in-lb	N·m	
40-181B [A5-1]	180 D	20.3	A
40-181C [A5-1]	180 D	20.3	A
40-193	150 D	16.9	A
40-195	150 D	16.9	M
40-196	90 D	10.2	A
40-198 [A5-3]	300 L (2)	33.9	A
40-199	90 D	10.2	A
40-199A	90 D	10.2	A
40-202 [A5-1]	300 L (1)	33.9	A
40-203 [A5-4]	290-300 L (2)	32.8-33.9	A
40-204 [A5-4]	290-300 L (2)	32.8-33.9	A
40-205 [A5-1]	180 D	20.3	M
40-210 [A5-6]	150 L (2)	16.9	M
40-211 [A5-3]	300 D	33.9	M
040-21101 [A5-3]	300 L (2)	33.9	M
40-212 [A5-1]	150 L (2)	16.9	M
40-223	90 D	10.2	A
40-230		(7)	M
40-234	90 D	10.2	A
40-239 [A5-6]	300 L (2)	33.9	A
040-23901 [A5-6]	300 L (2)	33.9	A
40-240A [A5-6]	125 L (2)	14.1	M
40-255 [A5-1]	90-100 L (2)	10.2-11.3	M
40-256	135-145 D	15.3-16.4	M
40-258	300 D	33.9	(1)
40-259 [A5-1]	95-105 L (2)	10.7-11.8	M
40-260 [A5-1]	95-105 L (2)	10.7-11.8	M
40-262A [A5-6]	90 L (2)	10.2	M
40-262AA [A5-6]	90-100 L (2)	10.2-11.3	M
40-270 [A5-6]	115-135 L (2)	13.0-15.3	M
40-273 [A5-5]	300 L (2)	33.9	A
40-273A [A5-4]	290-300 L (2)	32.8-33.9	A
40-273B [A5-4]	290-300 L (2)	32.8-33.9	A
40-276 [A5-6]	90-100 L (2)	10.2-11.3	M
40-279 [A5-3]	300 L (2)	33.9	M
40-279A	300 L (3)	33.9	M
40-281	90 D	10.2	M
40-289 [A5-1]	300 L (2)	33.9	M
40-293 [A5-6]	180-190 L (2)	20.3-21.5	M
40-307	75 D	8.5	M
40-308	75 D	8.5	M
40-403	150 D	16.9	A
40-406	150 D	16.9	M
40-406A	150 D	16.9	M
40-406B	150 D	16.9	M
40-406C	150 D	16.9	M
40-407	150 D	16.9	M
40-414	150 D	16.9	M
40-414A	150 D	16.9	M
40-417 [A5-7]	115-125 L (3)	13.0-14.1	A
40-418 (4)	150 D	16.9	A
40-418A (4)	150 D	16.9	A
40-418B (8)	150 D	16.9	A
40-418C (4)	150 D	16.9	A

Wheel Assembly	Bolt Torque		Wheel Matl
	in-lb	N·m	
40-418D (4)	150 D	16.9	A
40-423 [A5-8]	170-190 L (3)	19.2-21.5	A
40-426 (4)	150 D	16.9	A
40-426A (8)	150 D	16.9	A
40-426B	150 D	16.9	A
40-426C	150 D	16.9	A
40-426D (4)	150 D	16.9	A
40-432 [A5-1]	115-125 L (3)	13.0-14.1	A
40-434 [A5-6]	315-325 L (3)	35.6-36.7	A
40-450	105-115 L (2)	11.9-13.0	A
40-455	150 D	16.9	A
40-459	150 D	16.9	M
040-46900 [A5-1]	115-125 L (3)	13.0-14.1	M
40-481 [A5-1]	290-300 L (2)	32.8-33.9	A
40-483 [A5-1]	290-300 L (3)	32.8-33.9	M
C-30174-1	95 D	10.7	(1)
C-30179	95 D	10.7	(1)
D-30204	95 D	10.7	(1)
D-30255	195 D	22.0	(1)
D-30260	195 D	22.0	(1)
D-30260-1	195 D	22.0	(1)
D-30291-1	195 D	22.0	A
D-30291-2	195 D	22.0	A
D-30291-3	195 D	22.0	A
D-30291-4	195 D	22.0	A
D-30291-5	195 D	22.0	A
D-30291-6	195 D	22.0	A
D-30380	95 D	10.7	A
C-30480	195 D	22.0	(1)
D-30500	145 D	16.4	A
D-30500-1	145 D	16.4	A
D-30570	195 D	22.0	A
D-30580	195 D	22.0	(1)
D-30585	195 D	22.0	(1)
D-30660-1	145 D	16.4	A
D-30660-2	145 D	16.4	A
D-30660-3	145 D	16.4	A
D-30660-4	145 D	16.4	A
D-30660-5	145 D	16.4	A
D-30660-6	145 D	16.4	A
D-30660-7	145 D	16.4	A
D-30660-8	145 D	16.4	A
D-30660-9	145 D	16.4	A
D-30660-10	145 D	16.4	A
D-30665	145 D	16.4	A
D-30665-1	145 D	16.4	A

F. Wheel Assembly Torque Values

Table G. Tire Inflation Valve Stem Torque provides the recommended torque value for the applicable inflation valve of listed wheel assemblies in section F.

A code following the P/N, e.g. [A5-#] will correspond to the code in Table G.

G. Tire Inflation Valve Stem Torque

Inflation Valve Code Dash No. [A5-#]	Inflation Valve P/N	Recommended Torque	
		in-lb	N•m
A5-1	160-00700	50-60	5.7-6.8
A5-2	160-00900	165-200	18.7-22.6
A5-3	160-01100	75-100	8.4-11.3
A5-4	160-01200	35-45	4.0-5.1
A5-5	160-01500	70-80	7.9-9.0
A5-6	160-01900	50-60	5.7-6.8
A5-7	160-02000	25-35	2.8-4.0
A5-8	160-01900	45-55	5.08-6.21

H. Back Plate Tie Bolt Torque

A “D” shown adjacent to the torque value indicates the value to be a “Dry” torque only. An “L” shown adjacent to the torque value indicates a “Lube” torque only. Lube requires the application of a thread lubricant to all friction surfaces of the hardware prior to torquing. Only use the thread lubricant specified for your brake assembly. A flag note will specify which thread lubricant to use. Overtorquing (exceeding these values) could cause depressions in the brake cylinder, which result in dragging or bound up brakes. Use a torque wrench when installing back plate bolts to ensure the proper torquing values are attained. Replace the back plate tie bolts with approved bolts found at clevelandwheelandbrake.com. Depressions in the brake cylinder (surface A) exceeding 0.005 inch (0.127 mm) deep require replacement of the brake cylinder.

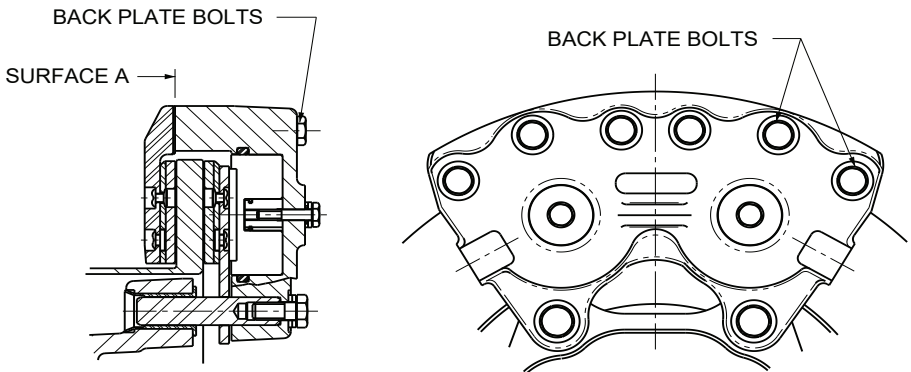

Figure A3 – Back Plate Tie Bolts

Table Flag Note Legend:

Material Column Designations:

“A” Aluminum “M” Magnesium “S” Steel

(1) For assistance contact the Technical Services Hotline (page i).

Thread Lubricant:

(2) Use SAE AMS2518 (ref MIL-T-5544).

(3) Use MIL-PRF-83483 (Molydisulphide).

H. Back Plate Tie Bolt Torque

Brake Assembly	Bolt Torque		Matl		Brake Assembly	Bolt Torque		Matl	
	in-lb	N•m	Housing	Torque Plate		in-lb	N•m	Housing	Torque Plate
35-200A	60 D	6.8	A	S	30-52G	90 D	10.2	M	S
30-4	60 D	6.8	A	S	30-52H	90 D	10.2	M	S
30-5	60 D	6.8	A	S	30-52K	90 D	10.2	M	S
30-6	60 D	6.8	A	S	30-52L	75-80 D	8.5-9.0	M	N/A
30-7	60 D	6.8	A	S	30-52M	90 D	10.2	M	S
30-4	60 D	6.8	A	S	30-52N	90 D	10.2	M	S
37-200-2	90 D	10.2	A	S	30-52P	90 D	10.2	M	S
30-9	75-80 D	8.5-9.0	A	S	30-52Q	90 D	10.2	M	S
30-9A	75-80 D	8.5-9.0	A	S	30-52S	90 D	10.2	M	S
30-9C	75-80 D	8.5-9.0	A	S	30-52T	90 D	10.2	M	S
30-9D	75-80 D	8.5-9.0	A	S	30-52U	90 D	10.2	M	S
30-9E	75-80 D	8.5-9.0	A	S	30-52V	90 D	10.2	M	S
3000-250	90 D	10.2	A	S	30-52W	90 D	10.2	M	S
3000-500	90 D	10.2	A	S	30-52X	90 D	10.2	M	S
30-18	75-80 D	8.5-9.0	A	S	30-52Y	90 D	10.2	M	S
30-19	75-80 D	8.5-9.0	A	S	30-52Z	90 D	10.2	M	S
30-19A	75-80 D	8.5-9.0	A	S	30-52AA	90 D	10.2	M	S
30-21	65-75 D	7.3-8.5	A	S	30-52AB	90 D	10.2	M	S
30-23	65-75 D	7.3-8.5	A	N/A	30-52AC	90 D	10.2	M	S
30-23A	65-75 D	7.3-8.5	A	N/A	30-53	75-80 D	8.5-9.0	M	S
30-23B	65-75 D	7.3-8.5	A	N/A	30-53A	75-80 D	8.5-9.0	M	S
30-23C	65-75 D	7.3-8.5	A	N/A	30-54	90 D	10.2	M	A
30-23D	65-75 D	7.3-8.5	A	N/A	30-54A	90 D	10.2	M	A
30-24	65-75 D	7.3-8.5	A	S	30-54B	90 D	10.2	M	S
30-28B	80-90 D	9.0-10.2	M	M	30-54C	85-90 D	9.6-10.2	M	A
30-28C	80-90 D	9.0-10.2	M	M	30-55	75-80 D	8.5-9.0	M	S
30-28D	80-90 D	9.0-10.2	M	M	30-55A	75-80 D	8.5-9.0	(1)	(1)
30-30	90 D	10.2	M	S	30-55B	75-80 D	8.5-9.0	M	S
30-31	1/4-28	9.6-10.2	A	S	30-56	75-80 D	8.5-9.0	M	S
	85-90 D				30-56A	75-80 D	8.5-9.0	M	S
	3/8-24				30-56B	75-80 D	8.5-9.0	M	S
	125-150 D				14.0-17.0	30-56C	75-80 D	8.5-9.0	M
30-32	65-75 D	7.3-8.5	A	S	30-56D	75-80 D	8.5-9.0	M	S
30-32A	65-75 D	7.3-8.5	A	S	30-56F	75-80 D	8.5-9.0	M	S
30-32B	65-75 D	7.3-8.5	A	S	30-58A	75-80 D	8.5-9.0	(1)	(1)
30-32C	65-75 D	7.3-8.5	A	S	30-58B	75-80 D	8.5-9.0	M	(1)
30-32E	65-75 D	7.3-8.5	A	S	30-59	75-80 D	8.5-9.0	M	S
30-35	65-75 D	7.3-8.5	A	S	30-59A	75-80 D	8.5-9.0	M	S
30-40	60 D	6.8	A	S	30-59E	75-80 D	8.5-9.0	M	S
30-40A	75-80 D	8.5-9.0	A	S	30-60	75-80 D	8.5-9.0	A	S
30-41	65-75 D	7.3-8.5	A	N/A	30-60A	65-75 D	7.3-8.5	A	S
30-41A	90 D	10.2	A	S	30-60B	65-75 D	7.3-8.5	A	S
30-41B	65-75 D	7.3-8.5	A	N/A	30-61	90 D	10.2	M	S
30-45	60 D	6.8	A	S	30-61A	90 D	10.2	M	S
30-51	65-75 D	7.3-8.5	A	S	30-61B	65-75 D	7.3-8.5	M	S
30-51A	65-75 D	7.3-8.5	A	S	30-61D	90 D	10.2	M	S
30-51B	65-75 D	7.3-8.5	A	S	30-61E	90 D	10.2	M	S
30-52	90 D	10.2	M	S	30-61F	90 D	10.2	M	S
30-52A	90 D	10.2	M	S	30-63	75-80 D	8.5-9.0	M	S
30-52B	90 D	10.2	M	S	30-63A	75-80 D	8.5-9.0	M	S
30-52D	90 D	10.2	M	S	30-63B	75-80 D	8.5-9.0	M	S
30-52E	90 D	10.2	M	S	30-63D	75-80 D	8.5-9.0	M	S
30-52F	90 D	10.2	M	S	30-63E	75-80 D	8.5-9.0	M	S

H. Back Plate Tie Bolt Torque

Brake Assembly	Bolt Torque		Matl	
	in-lb	N•m	Housing	Torque Plate
30-63F	75-80 D	8.5-9.0	M	S
30-63J	75-80 D	8.5-9.0	M	S
30-63K	75-80 D	8.5-9.0	M	S
30-63M	75-80 D	8.5-9.0	M	S
30-63P	75-80 D	8.5-9.0	M	S
30-63Q	75-80 D	8.5-9.0	M	S
30-63S	75-80 D	8.5-9.0	M	S
30-65	75-90 D	8.5-10.2	M	S
30-65A	75-90 D	8.5-10.2	M	S
30-65E	75-90 D	8.5-10.2	M	S
30-66	90 D	10.2	M	A
30-66A	90 D	10.2	M	M
30-66B	90 D	10.2	M	A
30-66C	90 D	10.2	M	A
30-66D	90 D	10.2	M	(1)
30-66F	90 D	10.2	M	M
30-66G	80-90 D	9.0-10.2	M	A
30-66H	75-90 D	8.5-10.2	M	S
30-67	85-90 D	9.6-10.2	A	A
30-67A	85-90 D	9.6-10.2	A	A
30-67B	85-90 D	9.6-10.2	A	A
30-67C	85-90 D	9.6-10.2	A	A
30-67D	85-90 D	9.6-10.2	A	A
30-67E	85-90 D	9.6-10.2	A	A
30-67X	85-90 D	9.6-10.2	A	A
30-68	75-80 D	8.5-9.0	M	M
30-68A	75-80 D	8.5-9.0	M	M
30-68B	75-80 D	8.5-9.0	M	M
30-69A	85-95 D	9.6-10.7	M	M
30-69B	90 D	10.2	M	M
37-200A	65-70 D	7.3-7.9	A	S
30-74B	60-75 D	6.8-8.5	M	M
30-75	75-80 D	8.5-9.0	A	S
30-75A	75-80 D	8.5-9.0	A	S
30-75B	75-80 D	8.5-9.0	A	S
30-75X	75-80 D	8.5-9.0	A	S
30-79	90 D	10.2	A	S
30-79A	90 D	10.2	A	S
30-79B	90 D	10.2	A	S
30-83	90 D	10.2	M	S
30-83A	90 D	10.2	M	S
30-84	80-90 D	9.0-10.2	A	N/A
30-88	75-80 D	8.5-9.0	M	A
30-89	80-90 D	9.0-10.2	A	A
30-89A	80-90 D	9.0-10.2	A	A
30-89B	80-90 D	9.0-10.2	A	A
30-89C	80-90 D	9.0-10.2	A	A
30-89E	80-90 D	9.0-10.2	A	A
30-93	80-90 D	9.0-10.2	M	M
30-93A	80-90 D	9.0-10.2	M	M
30-93B	80-90 D	9.0-10.2	M	M
30-93C	80-90 D	9.0-10.2	M	M
30-93D	80-90 D	9.0-10.2	M	M
30-93E	90-100 D	10.2-11.3	M	M
30-94	80-90 D	9.0-10.2	A	A
30-95	60 D	6.8	(1)	(1)
30-95A	60 D	6.8	M	M
30-95B	60 D	6.8	M	M
30-96	60 D	6.8	M	S
30-97	80-90 D	9.0-10.2	A	M
30-98	80-90 D	9.0-10.2	A	A
30-98A	80-90 D	9.0-10.2	A	A
30-98B	80-90 D	9.0-10.2	A	A
30-98C	80-90 D	9.0-10.2	A	A
30-98D	80-90 D	9.0-10.2	A	A
30-99	75-80 D	8.5-9.0	M	A
30-99A	75-80 D	8.5-9.0	M	M
30-100	75-80 D	8.5-9.0	M	M
30-106	80-90 D	9.0-10.2	M	M
30-107	85-90 D	9.6-10.2	A	M
30-107A	85-90 D	9.6-10.2	A	M
30-107B	85-90 D	9.6-10.2	A	M
30-107C	85-90 D	9.6-10.2	A	M
30-107D	85-90 D	9.6-10.2	A	M
30-107E	80-95 D	9.0-10.7	A	M
30-111	80-90 D	9.0-10.2	A	A
30-113	80-90 D	9.0-10.2	A	M
30-113A	80-90 D	9.0-10.2	A	M
30-123	80-90 D	9.0-10.2	M	M
30-127	90 D	10.2	M	S
30-127A	90 D	10.2	M	S
30-127C	90 D	10.2	M	S
30-127D	90 D	10.2	M	S
30-129	75-90 D	8.5-10.2	M	S
30-131	80-90 D	9.0-10.2	A	M
30-133	75-80 D	8.5-9.0	M	S
30-138	80-90 D	9.0-10.2	M	M
30-139	75-80 D	8.5-9.0	M	S
30-141	150 D	16.9	A	M
30-142	150 D	16.9	A	M
30-143	150 D	16.9	A	M
30-144	85-90 D	9.6-10.2	A	M
30-144A	85-90 D	9.6-10.2	A	M
30-144B	85-90 D	9.6-10.2	A	M
30-145	80-90 D	9.0-10.2	M	M
30-146	85-90 D	9.6-10.2	A	M
30-146A	85-90 D	9.6-10.2	A	A
30-149	80-90 D	9.0-10.2	A	A
30-158	80-90 D	9.0-10.2	M	M
30-159	85-90 D	9.6-10.2	A	M
30-159A	85-90 D	9.6-10.2	A	M
30-159B	85-90 D	9.6-10.2	A	M
30-159C	85-90 D	9.6-10.2	A	M
30-163	85-90 D	9.6-10.2	M	A
30-164	75-80 D	8.5-9.0	M	S
30-170	80-85 D	9.0-9.6	A	A

H. Back Plate Tie Bolt Torque

Brake Assembly	Bolt Torque		Matl	
	in-lb	N•m	Housing	Torque Plate
30-176	85-90 D	9.6-10.2	A	A
30-181A	75-80 D	8.5-9.0	A	S
30-182	85-90 D	9.6-10.2	M	A
30-182A	85-90 D	9.6-10.2	M	A
30-184	80-90 D	9.0-10.2	A	A
30-195	85-90 D	9.6-10.2	A	A
30-195A	85-90 D	9.6-10.2	A	A
30-210	80-85 L (2)	9.0-9.6	A	A
30-210A	80-85 L (3)	9.0-9.6	A	A
30-210C	80-85 L (3)	9.0-9.6	A	A
30-214	75-80 D	8.5-9.0	M	S
30-214B	75-80 D	8.5-9.0	M	S
30-220	85-90 D	9.6-10.2	A	M
30-224	75-80 D	8.5-9.0	M	S
30-231	80-90 D	9.0-10.2	A	A
30-233	90 D	10.2	M	S
30-233A	90 D	10.2	M	S
30-233B	90 D	10.2	M	S
30-233C	90 D	10.2	M	S
30-233E	85-95 D	9.6-10.2	M	S
30-233E RH	85-95 D	9.6-10.2	M	S
30-236	75-80 D	8.5-9.0	M	N/A
30-239	75-80 D	8.5-9.0	M	S
30-239A	75-80 D	8.5-9.0	M	S
30-239B	75-80 D	8.5-9.0	A	S
30-241	90 L (3)	10.2	A	S
30-269	90 D	10.2	M	A
30-280	85-90 D	9.6-10.2	A	A
30-290	85-90 D	9.6-10.2	A	S
30-293	85-90 D	9.6-10.2	A	S
30-293 RH	85-90 D	9.6-10.2	A	S
30-308	75-80 D	8.5-9.0	M	S
30-312	85-90 D	9.6-10.2	A	S
C-30018	120-130 D	13.6-14.7	A	S
C-30018-1	120-130 D	13.6-14.7	A	S
C-30018-2	120-130 D	13.6-14.7	A	S
C-30018-3	120-130 D	13.6-14.7	A	S
C-30018-4	120-130 D	13.6-14.7	A	S
C-30018-5	120-130 D	13.6-14.7	A	S
C-30018-6	120-130 D	13.6-14.7	A	S
C-30018-7	120-130 D	13.6-14.7	A	S
D-30118-3	100-110 D	11.3-12.4	A	S
D-30118-4	100-110 D	11.3-12.4	A	S
D-30118-5	100-110 D	11.3-12.4	A	S
D-30118-6	100-110 D	11.3-12.4	A	S
D-30118-7	100-110 D	11.3-12.4	A	S
D-30118-8	100-110 D	11.3-12.4	A	S
D-30118-9	100-110 D	11.3-12.4	A	S
D-30118-10	100-110 D	11.3-12.4	A	S
C-30764-5	120-130 D	13.6-14.7	A	S
C-30764-6	120-130 D	13.6-14.7	A	S
C-30764-7	120-130 D	13.6-14.7	A	S
D-30793-3	100-110 D	11.3-12.4	A	S

Brake Assembly	Bolt Torque		Matl	
	in-lb	N•m	Housing	Torque Plate
D-30793-4	100-110 D	11.3-12.4	A	S
D-30793-5	100-110 D	11.3-12.4	A	S
D-30793-6	100-110 D	11.3-12.4	A	S

I. Special Tools

Item	Part No.	Description
CWBS O-Ring Extractor Kit	199-18	Consists of Multi-hook, Multi-ramp & Case
Brake Line Bleeder	087-00500	The brake line bleeder can be used to service all CWBS hydraulic brake assemblies or any other brake assembly utilizing the 079-00300 FC6446) Bleeder Screw.

J. Elastomeric Compound Lubricants

Pneumatic Applications

Grease per MIL-G-4343

Royco 43 – Royal Lubricants Co., East Hanover, NJ

Aeroshell 43 – Royal Lubricants Co., Inc., East Hanover, NJ

Cosmolube 615 – Houghton International, Inc., Fogelsville, PA

Other:

55 O-Ring Lubricant - Dow Corning Corp., Midland, MI

Hydraulic Applications - Use fluids compatible with the system

MIL-H-5606 / MIL-H-83282 (Red Oils)

Skydrol – Only compatible with itself

K. Lubricants

Wheel Bearing Grease – Refer to Topic F, Bearing Grease paragraph

MIL-PRF-81322, Grade 2 or DOD-G-24508A

(Aeroshell Grease 22) Shell Oil Company, Metairie, LA

Mobil Aviation Grease SHC 100

ExxonMobil Oil Corp., Beaumont, TX

HCF Grease P/N 605 (Amphibious)

BG Products, Wichita, KS

OMNI Waterproof Green Grease, No. 2 (Amphibious)

OMNI Lubricants, Lewisville, TX

Bolts/Nuts Thread Lubricant –

Only use the thread lubricant specified for your assembly

per SAE-AMS2518 (ref MIL-T-5544)

Armit Laboratories, Costa Mesa, CA

Royco 44 - Royal Lubricant, East Hanover, NJ

per MIL-PRF-83483 (Molydisulphide)

Moly-50 P/N 51094 – Fel-Pro Chemical Products L.P., Skokie, IL

K. Lubricants

Pipe Threads (Brake Cylinder Inlet Fittings) - Apply to first 3 threads
 Lubon #404EU - Oil Center Research (Balmar LLC), Lafayette, LA
 Loctite 567 Thread Sealant - Henkel Corp., Rocky Hill, CT
 Loctite 592 Thread Sealant w/PTFE - Henkel Corp., Rocky Hill, CT
 PPG JC5A Jointing Compound - PPG Aerospace PRC-DeSoto, Sylmar, CA

Anchor Bolts/Torque Plate Bushings

Amphibious Environment

Lubriplate X-357 Extreme Pressure Moly Lubricant

Non-Amphibious Environment

Silicone Spray

Dri-Slide® Multi-Purpose Lubricant

LPS Force 842® Dry Moly Lubricant

L. Repair Materials

Aluminum - Conversion Coating per MIL-C-5541, Class 1A, (Alodine)

Magnesium -

For parts surface pretreated per AMS-M-3171 (MIL-M-3171)
 (dull bronze to bright gold appearance)

- Surface pretreatment per AMS-M-3171 (MIL-M-3171)
 Type III (dip), Type VI (brush on), or Type VIII (dip)
- IRIDITE 15, MacDermid Inc., Waterbury, CT (800-325-4158)
 (use instructions furnished by Mfr. for AZ81 & AZ91 magnesium)

For parts pretreated with Oxsilan® (clear to iridescent appearance)

- Oxsilan® MG 0610, Chemetall Oakite, www.chemetall.com

M. Primers and Paints

Color	Sherwin Williams, Cleveland, OH www.sherwin-williams.com
White Paint	Primer: P60G2, P60G10, or PSE2130-WHITE Topcoat: F63W13 (White)
Silver Paint	Primer: P60G2, P60G10, or PSE2130-WHITE Topcoat: F63BXS58-4337 (Silver)
Silver Paint (brake discs)	Primer: P60G2, P60G10, or PSE2130-WHITE Topcoat: F63BXS58-4337 (Silver)

ZRC Products www.zrcworldwide.com

- ZRC Galvilite Cold Galvanizing Compound
(per MIL-PRF-26915A)

NOTE: Coatings other than those listed in this component maintenance manual may be used provided the coatings comply with the coating thickness and cure temperature limitations. Cleveland Wheel & Brake Systems is not responsible for the performance of coatings not listed in this component manual. Consult your local EPA regulations prior to using coatings not listed in this component maintenance manual.

N. Chemical Stripping Agents

For Magnesium alloys AZ81 and AZ

Turco Products (Carson, CA) www.hstna.com/turco/aviation.cfm

- Spray or brush on application:
Water Based Environmentally Advantaged Paint Remover
P/N T-6813 or T-6840S
- Tank type stripping application:
Diphase Hot Tank Paint Remover
P/N T-6813 or T-5668

NEW!

PERFORMANCE THAT GOES THE DISTANCE Aircraft brake discs engineered for longer life



- 70% longer wear life vs. standard discs
- 25% longer life vs. competitors
- Up to 50% increase in lining life operational impact

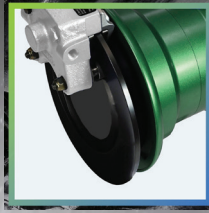
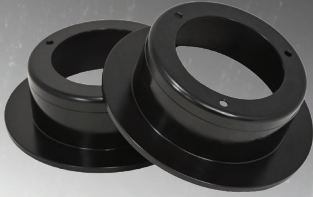

FREE Replacement Nameplates

Vinyl Laser Nameplate
Product Labels



Before completing service on your wheel and brake don't forget to replace the nameplate. Replacement nameplates are available for free at clevelandwheelandbrake.com



FREE Replacement Nameplates



Scan Here

FREE Minimum Thickness Brake Lining Gauge



For continued safe operation of your aircraft's wheels and brakes, Cleveland's External Design brake linings (both organic and metallic) must be replaced when reaching a minimum thickness of .100 inches (2.54 mm).

FREE Brake Lining Thickness 'Go / No-Go' Gauge



Scan Here

Cleveland Wheel & Brake Systems
1160 Center Road
Avon, Ohio 44011

Technical Services:
clevelandwheelandbrake.com/contact
1-800-BRAKING (1-800-272-5464)



AWBTSG0001-29